

# Technology and Benefits of Programmable Linear Position Sensors (Based on Inductive Measurement)

## Technology and Benefits of Programmable Linear Position Sensors

This white paper describes new technology that enables engineers to easily program key functions into a linear position sensor and the inductive sensing technology that makes it possible.

The benefits in general and some types of applications that can benefit from this technology will be covered along with some practical programming examples.

### Non-Contacting Inductive Measurement

The inductive measurement process described here is based on two electromagnetic principals– Ampère’s and Faraday’s laws. Ampère’s law states that magnetic field strength in space around an electric current flowing through a closed loop is proportional to the value of that current. Faraday’s law comes at electromagnetism from a different perspective. It states that a voltage will be induced in a coil from a change in the magnetic field around that coil and that it will be proportional to that change.

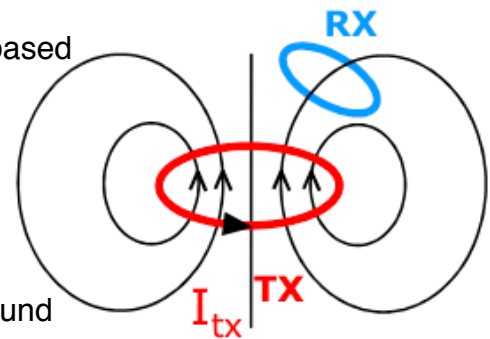

Applying these laws, a printed circuit board was developed with conductive traces shaped into sine and cosine patterns relative to each other. An AC current is applied to these traces with a 90° phase shift between the sine and cosine traces to simulate a coil.

The result is to produce two magnetic fields perpendicular to the plane of the traces. These fields are affected by a magnetic marker passing above them in sine and cosine wave patterns respectively. Adding these two fields together results in the formula:  $H \cdot \sin(x) \cdot \cos(\omega t) + H \cdot \cos(x) \cdot \sin(\omega t) = H \cdot \sin(\omega t + x)$ , where  $x$  is the position of the magnetic marker,  $t$  is time,  $\omega$  is the frequency of the waveform applied, and  $H$  is the strength of the magnetic field. It represents that the phase of the sum of the magnetic fields ( $\omega t + x$ ) at a distinct measurement point is directly proportional to the linear position  $x$ . The position marker sends the summation signal back to a receiving coil on the pc board.

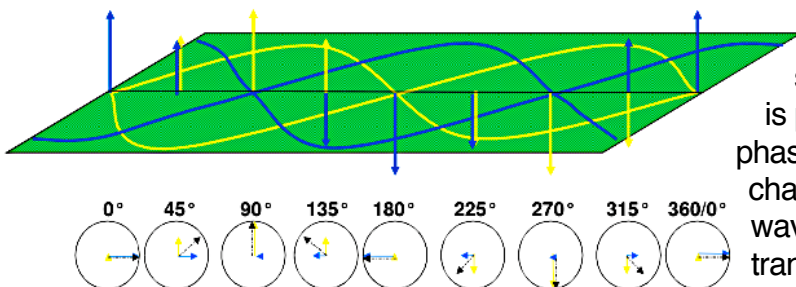

By measuring the phase shift between the outgoing and the received sinusoidal signals, a dc voltage can be produced that is proportional to the phase difference or phase shift caused by the position marker’s change in position. The circuitry generating the waveforms, measuring the phase shift and translating it into a dc value is shown on page 3.

## Technology and Benefits of Programmable Linear Position Sensors

### Benefits of Inductive Measurement

This inductive measurement technology offers benefits compared to earlier position measurement technology utilizing a mechanical wiper moving over a conductive track with contact.

It is inherently wear-free since there are no contacting parts. The position marker is attached to the application's moving part, the position of which needs to be measured, and is free-floating above the sensor.

Since only the position marker is subjected to potential shock and vibration from the application, shock, vibration and the dither those environmental effects could otherwise cause to the position sensor are eliminated.

This technology even exhibits immunity to external magnetic fields such as those created by nearby electric motors due to a design that operates in a narrow frequency range and filters out or rejects frequencies outside that range.

Finally, by using an inductive measurement technique, the same microprocessor based circuitry needed for that technology can be used to add programmable features to a position sensor.

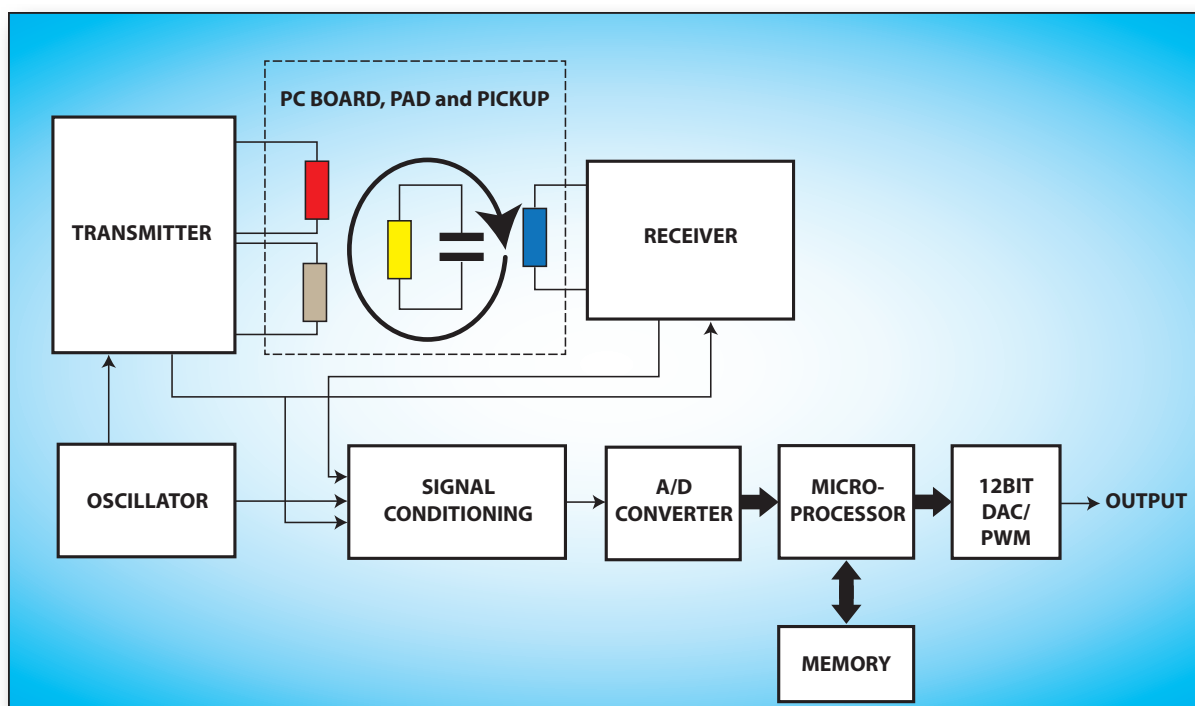

## Technology and Benefits of Programmable Linear Position Sensors

---

### Programmability and the Practical Benefits It Brings

Several useful parameters could be programmed including electrical measurement range, slope, position for minimum output voltage/current, position for maximum output voltage/current and offset.

The electrical measurement range sets both the minimum and maximum positions for which a change in output signal will occur. By setting these at values other than zero and full scale, applications that require a slope other than 1:1 could be accommodated. It could also be used to limit the output range to occur over a smaller portion of the travel range at specific starting and ending distances from physical end-points.

A negative slope might also be programmed so that the output value decreases as the stroke length increases.

Programming an offset would allow an output value other than 0 to represent a position of 0 inches.

With all this you'd image that there must be some benefits to using this technology in an application. And you'd be right. Here they are:

- In high noise environments, maximum noise rejection can be achieved by applying the entire output range to the actual travel length your application requires rather than the entire stroke length of the position sensor.

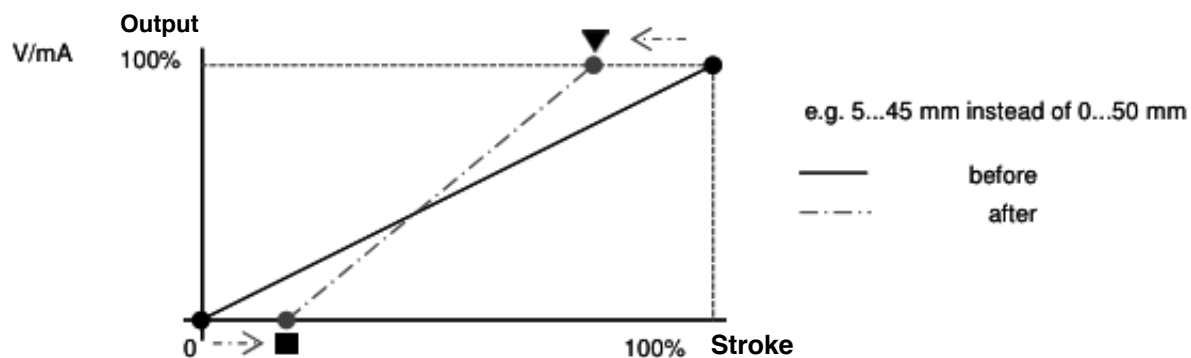

## Technology and Benefits of Programmable Linear Position Sensors

- By programming an offset, a sensor can be adjusted in seconds for deviations or tolerances in mounting the physical sensor without moving the sensor.

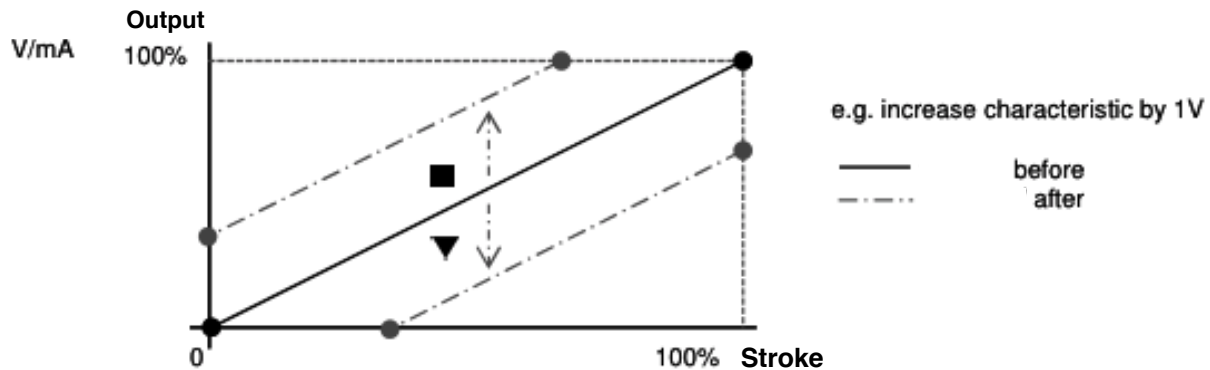

- Output voltage can be set to either a minimum or maximum threshold, say 1.0 V (L1) on the low end and 9.0 V (L2) on the high. So by programming limits to the output of the sensor, it can serve as an error detector. If the output is limited in this manner, and voltage falls outside of the set range, a cable fault - open or short - is likely occurring and a process monitor could be set to indicate a fault under these circumstances.

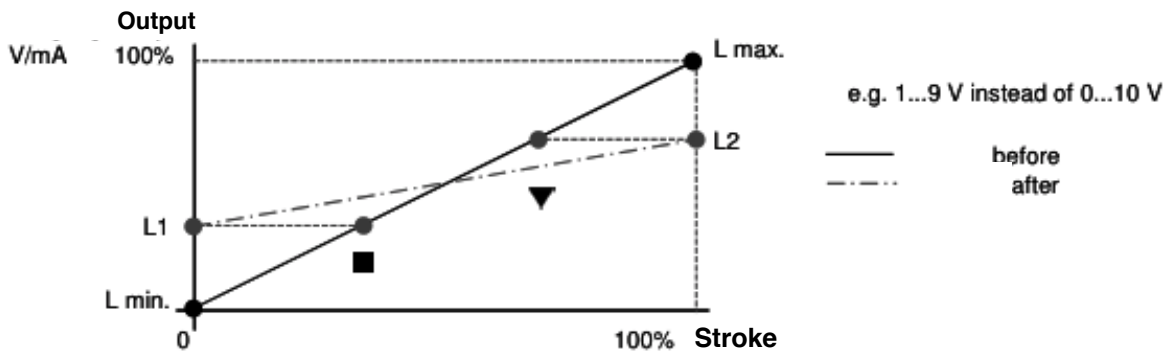

- By programming a sensor you can also eliminate the need for a programmable process monitor in some applications and use an inexpensive readout that simply displays values instead.

## Technology and Benefits of Programmable Linear Position Sensors

---

To sum up, new technology combines the benefits of non-contact linear position sensing with some essential programmability of a programmable controller all in a relatively small sensor package. This technology can help engineers in a number of applications including those where costs and/or development time can be saved with all control functions needed handled by the position sensor, applications requiring high accuracy over a small distance and applications with noisy environments.

An implementation of this technology is seen in Novotechnik's NovoPad and LS1 Series of position sensors, shown here. On these devices programming is accomplished by pressing the dual purpose LEDs/buttons according to published guidelines and observing the status of the LEDs. The square and triangle below the LEDs serve as a visual guide as to differentiate the LED/buttons in communicating which button to press.

A few of the applications that are using this technology are material handling equipment, crimping machines and position sensors for linear actuators.

To view Novotechnik's implementation of this technology including programming examples with charts, view: [www.novotechnik.com/LS1](http://www.novotechnik.com/LS1)

