

# Technology and Benefits of Advanced Inductive Technology for Linear Position Sensors

Unaffected by  
magnetic fields

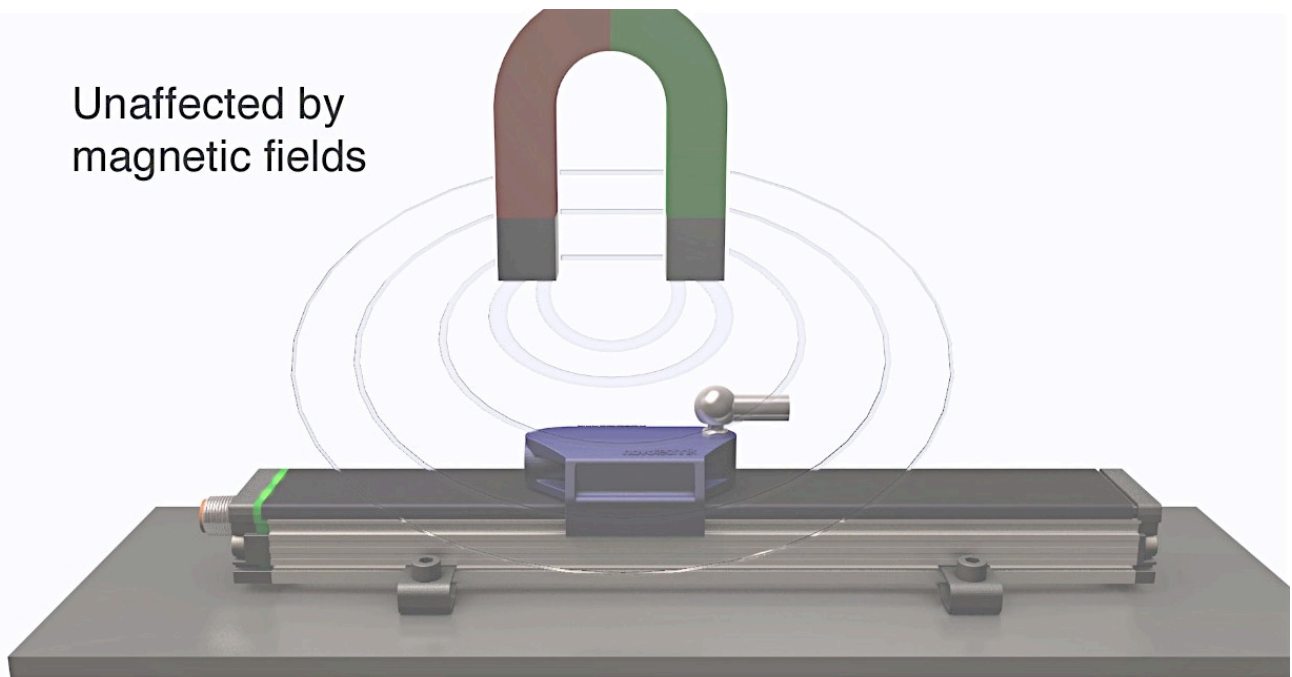

## Technology and Benefits of NovoPad™ Inductive Technology

This white paper describes new and improved technology that offers engineers specific advantages in speed, accuracy and reliability over previous linear position measurement technologies including magnetostrictive and prior inductive technologies.

The benefits in general and some types of applications that can benefit from this technology will be covered along with some practical programming examples.

### Touchless, Advanced Inductive Measurement

The inductive measurement process described here is based on two electromagnetic principals– Ampère’s and Faraday’s laws. Ampère’s law states that magnetic field strength in space around an electric current flowing through a closed loop is proportional to the value of that current. Faraday’s law comes at electromagnetism from a different perspective. It states that a voltage will be induced in a coil from a change in the magnetic field around that coil and that it will be proportional to that change.

Applying these laws, conductive traces shaped into sine and cosine patterns relative to each other are created on a printed circuit board. An AC current is applied to these traces with a 90° phase shift between the sine and cosine traces to simulate a coil.

The result is to produce two magnetic fields perpendicular to the plane of the traces. These fields are affected by a magnetic marker passing above them in sine and cosine wave patterns respectively. (see figure 1). Adding these two fields together results in the formula:

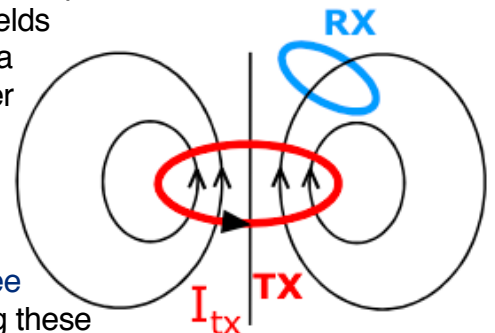

$H \cdot \sin(x) \cdot \cos(\omega t) + H \cdot \cos(x) \cdot \sin(\omega t) = H \cdot \sin(\omega t + x)$ , where  $x$  is the position of the magnetic marker,  $t$  is time,  $\omega$  is the frequency of the waveform applied, and  $H$  is the strength of the magnetic field. It represents that the phase of the sum of the magnetic fields ( $\omega t + x$ ) at a distinct measurement point is directly proportional to the linear position  $x$ . The position marker sends the summation signal back to a receiving coil on the pc board.

By measuring the phase shift between the outgoing and the received sinusoidal signals, a dc voltage can be produced that is proportional to the phase difference or phase shift caused by the position marker’s change in position.

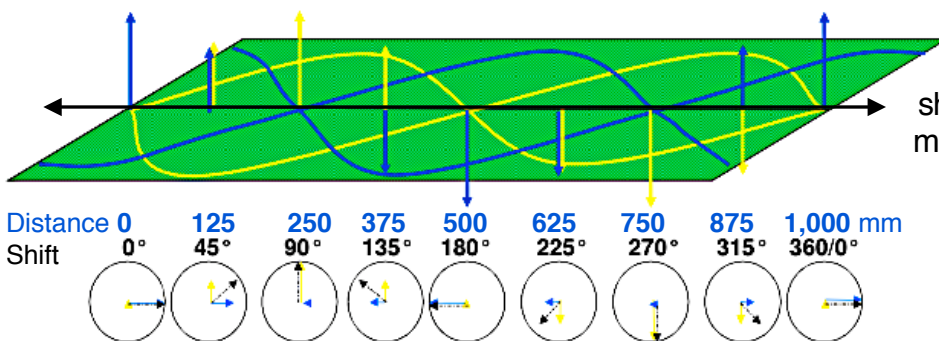

The circuitry generating the waveforms, measuring the phase shift based on the position

## Technology and Benefits of NovoPad™ Inductive Technology

of the marker moving along a linear path and translating it into a dc value representing the linear distance directly proportional to the phase-shift is shown in [figure 2](#).

Implementing this technology into products for use in measurement and control applications, Novotechnik developed and improved on a baseline system. An advanced inductive linear position sensor comprises a system of transmission and receiver coils mounted on the same circuit board within a robust sensor housing as well as in a separate “floating” position marker.

This active position marker is supplied by a high-frequency alternating field generated by the transmission coil.

Depending on the position, the position marker induces a current into the receiver coil system. The receiver coil system’s sine/cosine structures are divided into a coarse and a fine track. The coarse track detects the approximate position of the position marker, while the fine track is utilized for high-precision position sensing.

The phase relationship of the signals is the measure of the current position of the position marker and is converted into a

linear position signal by the electronics. This technology is protected by patents.

### Benefits of NovoPad Advanced Inductive Measurement

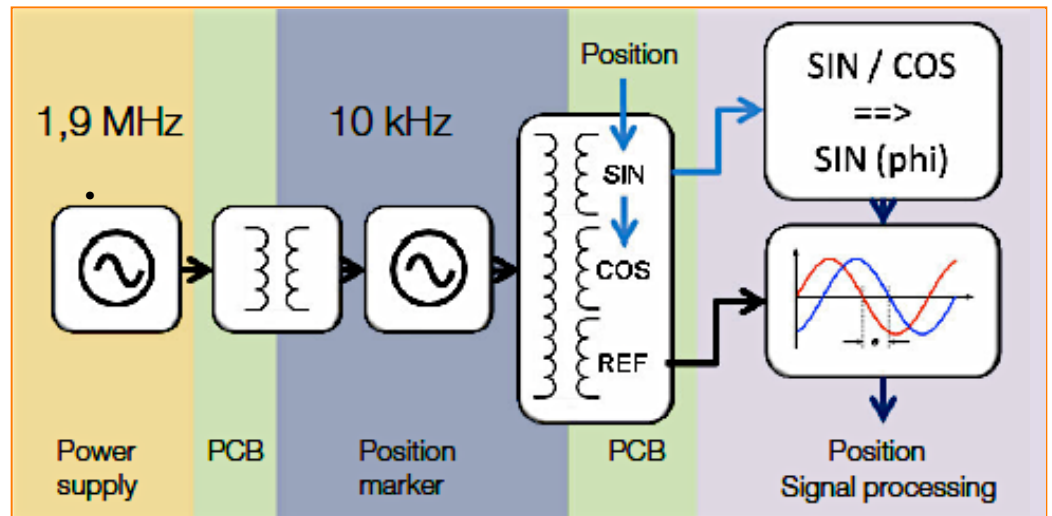

Figure 2

This inductive measurement technology offers benefits compared to legacy position measurement technologies including magnetostrictive or other inductive technology.

Like other touchless technologies, this is inherently wear-free since there are no contacting parts. The position marker is attached to the application’s moving part, the position of which needs to be measured, and is free-floating above the sensor. The similarities to other technologies end here.

NovoPad technology has several specific advantages over other position measurement technologies. These are as follows.

## Technology and Benefits of NovoPad™ Inductive Technology

---

1) NovoPad Inductive sensors exhibit immunity to external magnetic fields called electro-magnetic interference (EMI), such as those created by nearby electric motors or inverters due to a design that operates in a narrow frequency range and filters out or rejects frequencies outside that range.

2) Problems of spurious measurements from metal flakes or filings that occur due to magnetic pick up markers, used in

magnetostrictive devices, trapping flakes between the marker and sensor are avoided with NovoPad inductive technology. No false or erroneous readings from metal flakes.

3) NovoPad inductive technology is inherently much, much faster than magnetostrictive technology. Cycle times as fast as 1 msec are possible.

4) NovoPad inductive technology and supporting circuits are more stable and robust, accepting up to 20 g of vibration and 100 g of shock without reduction of accuracy or repeatability.

5) By using an inductive measurement technique, the same microprocessor based circuitry needed for that technology can be used to add programmable features to a position sensor.

6) Accuracy is high with absolute linearity to  $< \pm 0.025\%$  of full scale, resolution to  $10 \mu\text{m}$ , hysteresis  $\leq 10 \mu\text{m}$  and repeatability to  $10 \mu\text{m}$ .

### Programmability and its Practical Benefits

Several very useful functions and parameters have been programmed and verified through extensive testing. These include system functionality status, electrical measurement range, slope, position for minimum output voltage/current, position for maximum output voltage/current, offset and velocity of the marker.

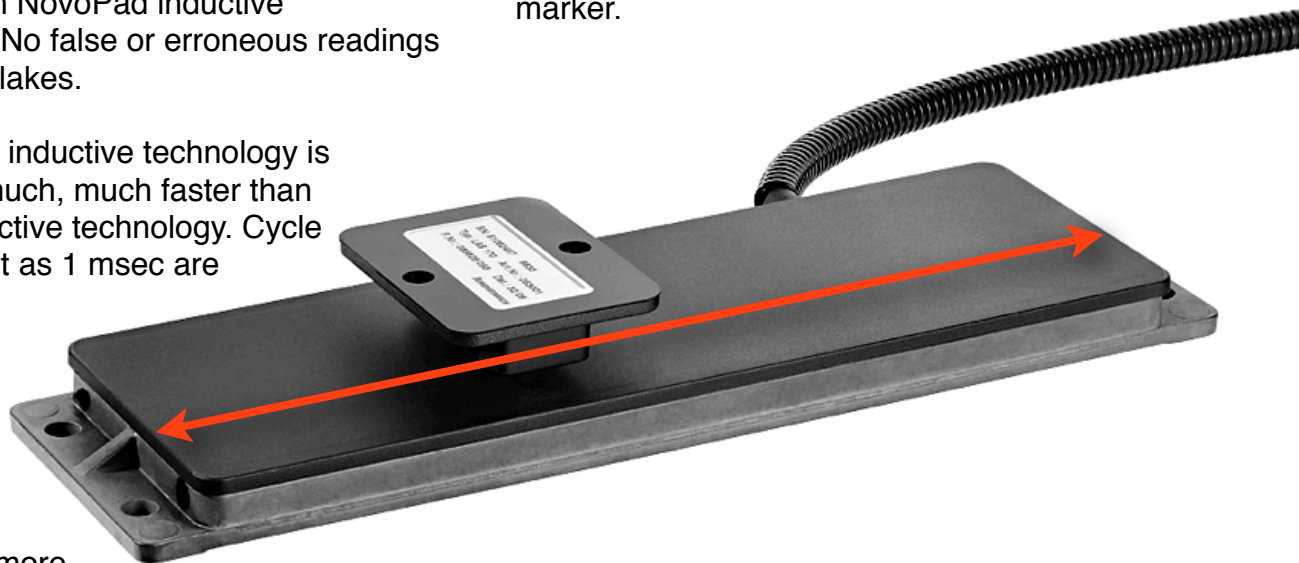

Descriptions and benefits of the programmable aspects are described and shown in the charts that follow.

## Technology and Benefits of NovoPad™ Inductive Technology

Starting with measurement range adjustments, these can be programmed through software then saved to a sensor.

The electrical measurement range sets both the minimum and maximum positions for which a change in output signal will occur. By setting these at values other than zero and full scale, applications that require a slope other than 1:1 can be accommodated. It could also be used to limit the output range to occur over a smaller portion of the travel range at specific starting and ending distances from physical end-points.

A negative slope might also be programmed so that the output value decreases as the stroke length increases. (See figure 3).

Programming an offset would allow an output value other than 0 to represent a position of 0 inches (or mm). It could also be combined with a slope change. (See figure 4).

Additional benefits of programmability include:

- Detecting the presence of a position marker and that it is being moved within the physical operational range of the sensor.
- Self-testing the measurement system.
- Instantly visually reporting the status of operation and marker presence through colored LEDs located on the sensor housing. The benefit here is your customer can give you accurate go-no go information on all the sensors in your machines while you are still at your desk.
- By programming an offset, a sensor can be adjusted in seconds for deviations or tolerances in mounting the physical sensor without moving the sensor.

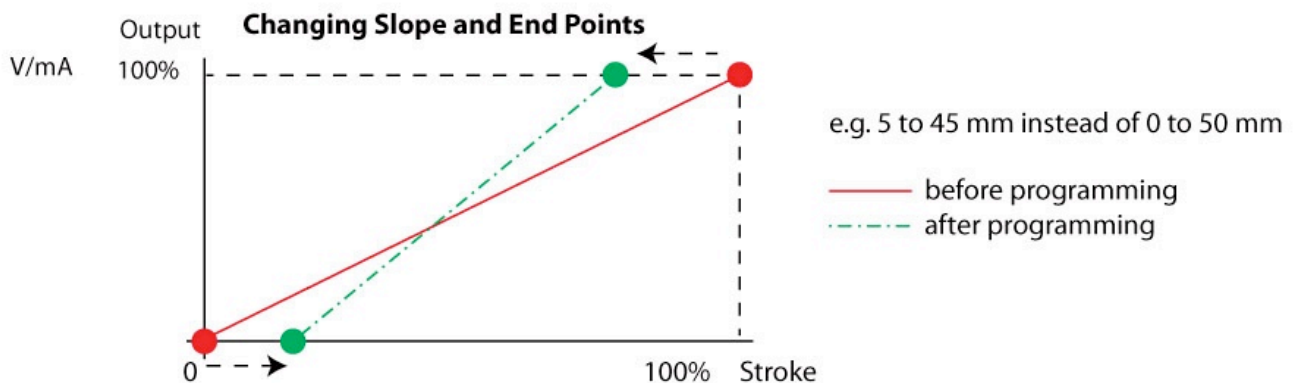

Figure 3



# Technology and Benefits of NovoPad™ Inductive Technology

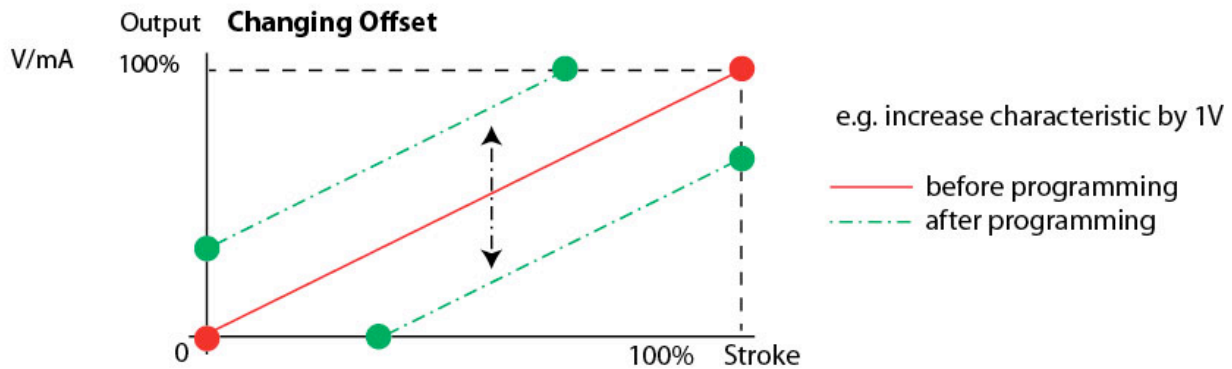

Figure 4

- In high noise environments, maximum noise rejection can be achieved by applying the entire output range to the actual travel length your application requires rather than the entire stroke length of the position sensor. (see figure 5).

- A unique device identifier can be stored so that user's PLCs can identify the physical location of each device at any time.

- By programming a sensor you can also eliminate the need for a programmable process monitor in some applications and use an inexpensive readout that simply displays values instead.

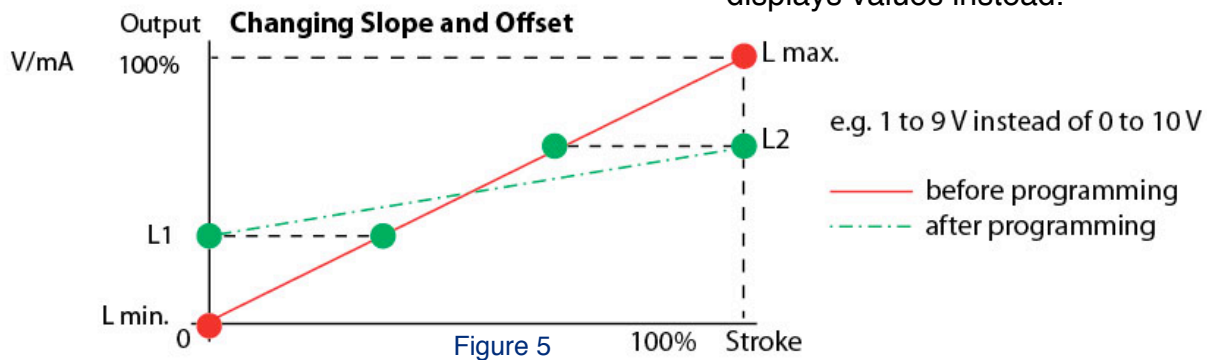

Figure 5

- Output voltage can be set to either a minimum or maximum threshold, say 1.0 V (L1) on the low end and 9.0 V (L2) on the high. So by programming limits to the output of the sensor, it can serve as an error detector. If the output is limited in this manner, and voltage falls outside of the set range, a cable fault - open or short - is likely occurring and a process monitor could be set to indicate a fault under these circumstances. (See figure 5).

## Technology and Benefits of NovoPad™ Inductive Technology

---

### Summary

Advanced inductive technology has many advantages over previous technologies that can have a meaningful impact on reliability in some existing applications as well as expand the environments where position sensing can be used or increase the design flexibility engineers have. So engineers can design their products for use in applications that:

- environments where intermittent or continuous problems are experienced with
- rely on high accuracy
- need high speed operation
- have customer sites where machine uptime is important and helped by constant visual operational status indication
- demand high reliability.

For a dynamic visual presentation of NovoPad advanced inductive technology view the **video** of the TF1 at [www.novotechnik.com/tf1](http://www.novotechnik.com/tf1) it highlights the advantages of the technology.

