

**NOVOTURN
Multi-turn Sensor
Non-contacting**

**RSM-2800
SSI**

Industrial



Special Features

- Non-contacting, magnetic
- Long life
- Measuring range 5040° or 5760° (14 or 16 turns)
- True-Power-On system: counts turns even when not powered. Patented non-volatile technology does not require gears or batteries
- Available with push-on coupling or marked shaft
- Easy mounting
- Protection class IP54 up to IP67
- Resolution up to 18 bits
- Linearity up to $\pm 0,03\%$
- Other configurations see separate data sheets

Applications

- Mechanical engineering
- Mobile machinery
- Driveline or steering systems
- Wire-actuated encoders
- Gate drives
- Motor sports

Multi-turn sensors that use the GMR technology (giant magneto resistance), provide absolute position values, do not require any reference signals and need no power supply or buffer battery for detecting the revolutions. The fact that rotations are detected even unpowered and the sensor does not lose its position information during a power failure, makes the RSM-2800 with its diameter of only 28 mm an extremely compact real True-Power-On rotary sensor.

The sensor operates magnetically and thus contactless allowing an extremely long life.

The sensor is able to detect angular positions over up to 16 revolutions with a high resolution up to 18 bits.

Description

Material	Housing: high grade, temperature resistant plastic PPS-GF40/SF50 Shaft: SS X8CrNiS18-9 1.4305 / AISI 303
Mounting	With 2 screws M4 and washers
Fastening torque of mounting	max. 180 Ncm
Bearing	Sintered bronze bushing
Electrical connection	Connector M12x1, A-coded with cable L = 0.15 m / Cable 4x 2x 0.25 mm ² (AWG 24), TPE, shielded

Mechanical Data

Dimensions	See dimension drawing
Mechanical travel	continuous
Permitted shaft load static or dynamic	20 N (axial / radial)
Torque	0.15 Ncm (IP54), 0.5 Ncm (IP65), 1.0 Ncm (IP67)
Weight	approx. 50 g

Ordering Specifications

Ordering Specifications

Preferred types printed in bold

- Delivery time up to 25 pcs. within 10 working days EXW
- Best low-volume pricing

Supply voltage U_b

- 1: $U_b = 24$ VDC
- 2: $U_b = 5$ VDC

Interface parameters

- 41: SSI 16 bits, Gray code, rising output characteristic cw
- 42: SSI 16 bits, Gray code, rising output characteristic ccw
- 43: SSI 25 bits (18 bits data), Gray code, rising output characteristic cw
- 44: SSI 25 bits (18 bits data), Gray code, rising output characteristic ccw
- 45: SSI 16 bits, Binary code, rising output characteristic cw
- 46: SSI 16 bits, Binary code, rising output characteristic ccw
- 47: SSI 25 bits (18 bits data), Binary code, rising output characteristic cw
- 48: SSI 25 bits (18 bits data), Binary code, rising output characteristic ccw

Electrical connection

- 432: Cable, 8-pole, shielded, L = 1 m
 - 531: Connector M12x1, 8-pin, with cable, shielded, L = 0.15 m
- Cable versions and assembled connectors on request

R S M - 2 8 3 2 - 2 1 4 - 1 4 1 - 4 3 2

Series

Mechanical version

- 2802: 6 mm shaft with flattening, IP54
 - 2832: 6 mm shaft with flattening, IP65**
 - 2862: 6 mm shaft with flattening, IP67
 - 2821: push-on coupling, IP54
 - 2841: push-on coupling, IP65**
 - 2871: push-on coupling, IP67
- Other shaft configurations on request

Number of turns for output characteristic

- 214: 14 turns = 5040°, measuring range controlled
- 216: 16 turns = 5760°, measuring range not controlled

Drawing

CAD data see
www.novotechnik.de/en/download/cad-data/

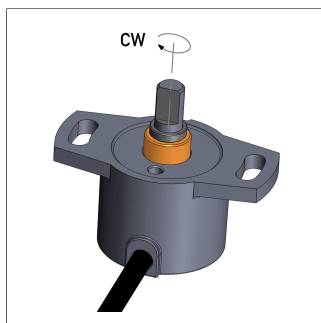
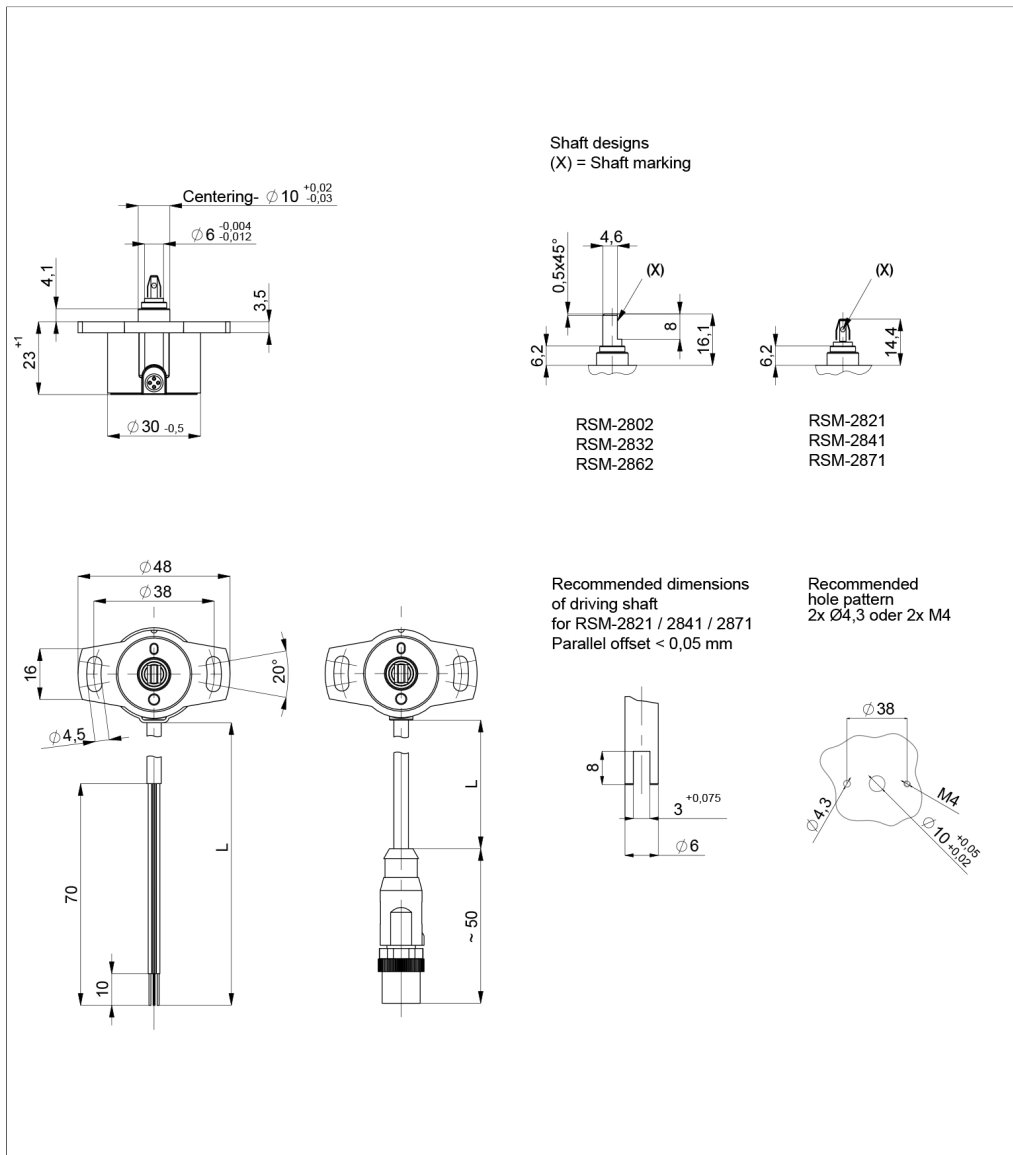

When the marking of the shaft is pointing towards the electrical outlet, the sensor output is located on an integer turn position.

Technical Data

Type	RSM-28 _-2_-14_-	RSM-28 _-2_-24_-
Measuring range	14 turns = 5040°, measuring range controlled 16 turns = 5760°, measuring range not controlled	
Protocol	SSI 16 and 25 bits	
Coding	Gray, Binary	
Inputs	RS-422 compatible, CLK lines via optocoupler galvanically isolated	
Monoflop time (tm)	20 ± 1 µs	
Update rate (internal)	1 kHz	
Absolute linearity	14 turns: ≤ ±0,036 %FS 16 turns: ≤ ±0,031 %FS	
Repeatability	≤ ±0,5°	
Hysteresis	≤ ±1°	
Temperature error	±0.1 %FS	
Supply voltage Ub	24 VDC (10 ... 32 VDC)	5 VDC (4.5 ... 5.5 VDC)
Current consumption w/o load	typ. 10 mA	typ. 20 mA
Polarity protection	yes (supply lines and outputs)	
Short circuit protection	yes (vs. GND, max. 1 min)	yes (vs. GND and supply voltage, max. 10 min)
Ohmic load at outputs	≥ 120 Ω	
Max. clock rate	100 kHz	
Insulation resistance (500 VDC)	≥ 10 MΩ	
Environmental Data		
Max. operational speed	800 rpm	
Vibration IEC 60068-2-6	20 g, 5 ... 2000 Hz, Amax = 0.75 mm	
Shock IEC 60068-2-27	50 g, 6 ms	
Protection class DIN EN 60529	IP54 / IP65 / IP67	
Operating temperature	-40 ... +85°C -25 ... +85°C (connector M12)	
Insensitivity to magnetic DC fields	< 15 mT	
Life	> 50 Mio. movements (mechanically)	
MTTF (IEC 60050)	173 years	179 years
EMC Compatibility		
EN 61000-4-2 ESD (contact/air discharge)	4 kV, 8 kV	
EN 61000-4-3 Electromagnetic fields (RFI)	10 V/m	
EN 61000-4-4 Fast transients (burst)	1 kV	
EN 61000-4-6 Cond. disturbances (HF fields)	10 V eff.	
EN 61000-4-8 Magnetic fields	30 A/m	
EN 55016-2-3 Radiated disturbances	Industrial and residential area	

Important:

While operation, care should be taken not to rotate the sensor shaft below 0° or above 5760°. Refer to install guide.
FS = Full scale: Signal span according to electrical measuring range

Connection Assignment

Signal	Connector code 5_ _	Cable code 4_ _
Supply voltage Ub	Pin 1	WH
GND	Pin 2	BN
CLK -	Pin 3	GN
CLK +	Pin 4	YE
Data -	Pin 5	GY
Data +	Pin 6	PK
Do not connect	Pin 7	BU
Do not connect	Pin 8	RD

Connect cable shielding to GND

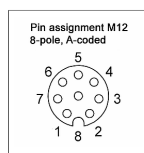

Technical Data Output Characteristics

Protocol

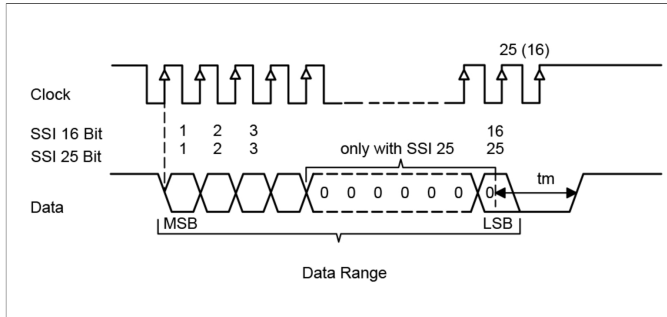

Connection

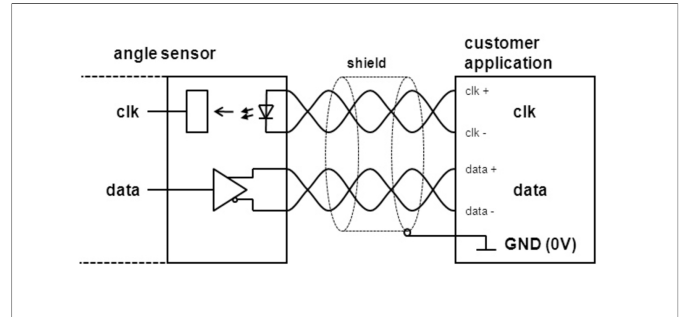

Output characteristic

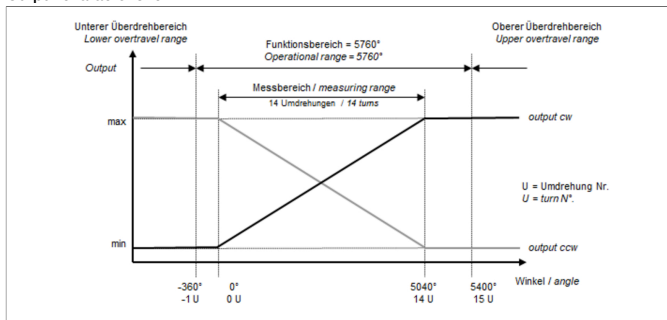

Output characteristic

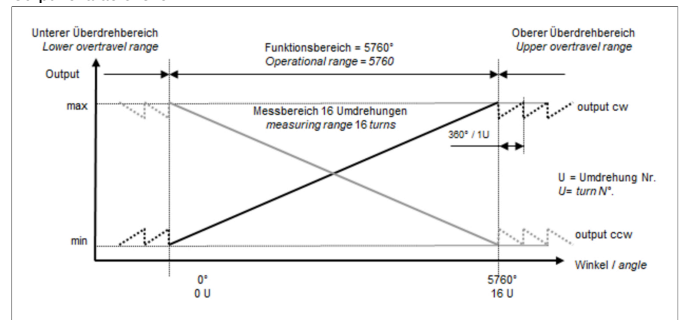

Sensor Mounting

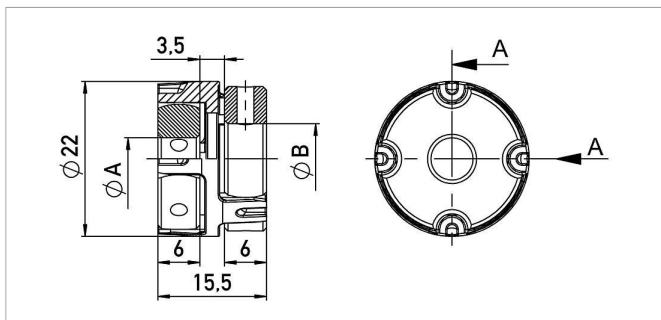
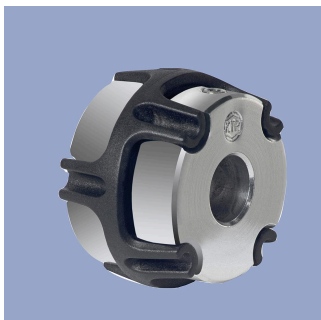

Z-106-G_
Backlash-free, double cardanic shaft coupling for $\varnothing 6$ mm to $\varnothing 6$ mm, $\varnothing 6.35$ mm or $\varnothing 10$ mm, mounting via 2 threaded pins with internal hexagon

Material Aluminium, PEEK
Operating temp. $-40 \dots +160^\circ\text{C}$
Transferable torque ≤ 1 Nm
Displacement rad. ≤ 0.1 mm, angl. $\leq 0.45^\circ$

P/N	Type	$\varnothing A / \varnothing B$ [mm]
400103910	Z-106-G-6	6 / 6
400103912	Z-106-G-6,35	6 / 6.35
400103913	Z-106-G-10	6 / 10

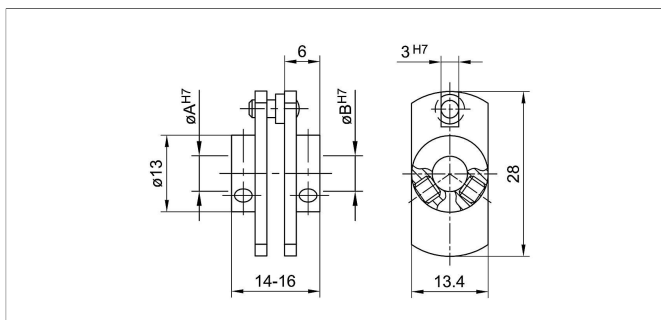
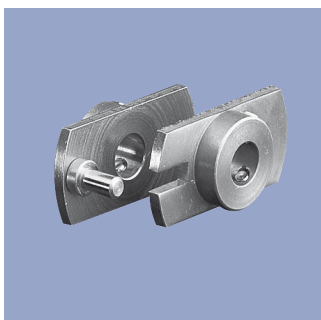

Z-104-G-6
Fork coupling with low backlash for $\varnothing 6$ mm. Mounting with 2 cylinder head screws M3 with internal hexagon. Angle screwdriver DIN 911 AF 1.5 included in delivery.

Material SS, ground driving pin
Displacement ≤ 1 mm

P/N	Type	$\varnothing A / \varnothing B$ [mm]
400005690	Z-104-G-6	6 / 6

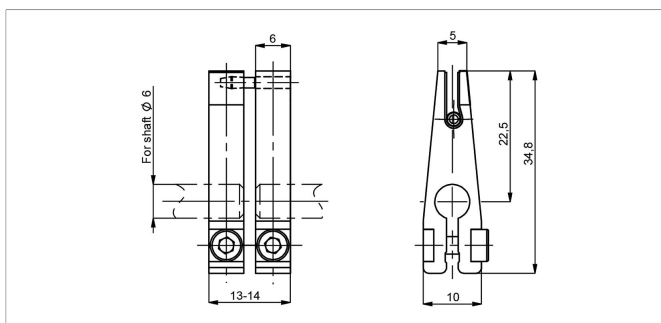
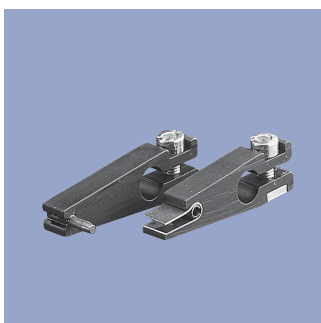

Z-105-G-6
Backlash-free fork coupling for $\varnothing 6$ mm. Mounting with 1 cylinder head screw M3 with internal hexagon. Angle screwdriver DIN 911 AF 2.5 included in delivery.

Material Aluminium, anodized (black)
Driving pin and spring hardened
Transferable torque ≤ 5 Ncm
Displacement ≤ 1 mm

P/N	Type
400005691	Z-105-G-6

Connecting Options on request



- M12 connector**
- Customized lengths
 - 3-, 4-, 6- and 8-pole versions
 - Protection class IP68
 - Ordering codes of standard versions see ordering specifications

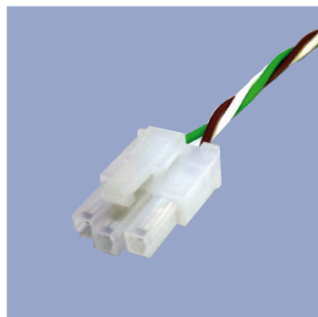

- Molex Mini Fit jr.**
- Customized length and lead wires
 - 3-, 4- and 6-pole versions
 - On request



- Tyco AMP Super Seal**
- Pin- and bushing housing
 - Customized lengths
 - 3-, 4- and 6-pole versions
 - Protection class IP67
 - On request



- Molex Mini Fit jr.**
- Customized length and lead wires
 - 3-, 4- and 6-pole versions
 - On request



- Deutsch DTM 04**
- Pin- and bushing housing
 - Customized lengths
 - 3-, 4- and 6-pole versions
 - Protection class IP67
 - On request



- ITT Cannon Sure Seal connector**
- Customized lengths
 - 3-, 4- and 6-pole versions
 - Protection class IP67
 - On request

Novotechnik U.S., Inc.
155 Northboro Road

Southborough, MA 01772
Phone 508 485 2244
Fax 508 485 2430
info@novotechnik.com
www.novotechnik.com



© Mar 20, 2026

The specifications contained in our datasheets are intended solely for informational purposes. The documented specification values are based on ideal operational and environmental conditions and can vary significantly depending on the actual customer application. Using our products at or close to one or more of the specified performance ranges can lead to limitations regarding other performance parameters. It is therefore necessary that the end user verifies relevant performance parameters in the intended application. We reserve the right to change product specifications without notice.