

**NOVOTURN  
Multiturn Sensor  
non-contacting**

Series RSM-2800

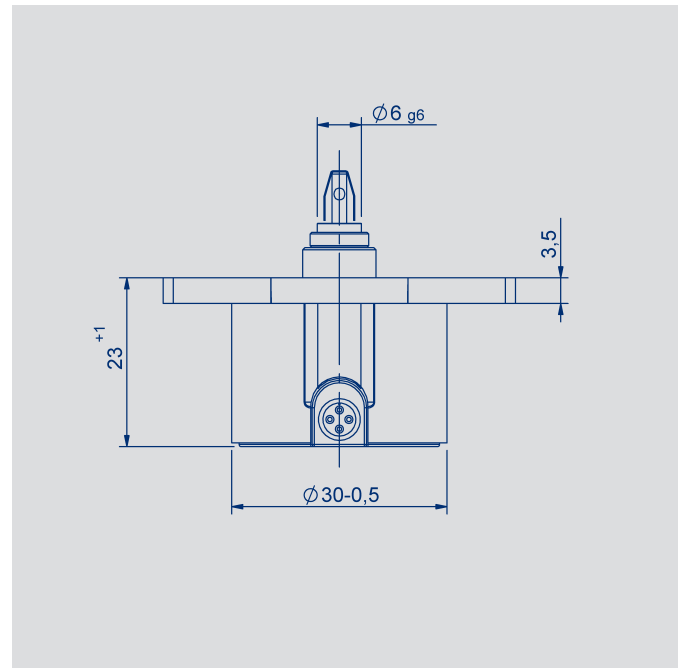

**Special features**

- Non-contacting, magnetic
- Long life
- Electrical range 720° up to 5760° in 360°-steps available (2 to 16 turns)
- True-Power-On System: counts turns even when not powered. Patented non-volatile technology does not require gears or batteries
- Available with push-on coupling or marked shaft
- Easy mounting
- Protection class IP54 up to IP67
- One-channel or multi-channel
- Resolution up to 18 bit
- Linearity up to  $\pm 0,03\%$

**Applications**

- Mechanical engineering
- Mobile machinery
- Driveline or steering systems
- Wire-actuated encoders
- Gate drives
- Motor sports

Multiturn sensors that use the GMR technology (giant magneto resistance), provide absolute position values, do not require any reference signals and need no power supply or buffer battery for detecting the revolutions. The fact that rotations are detected even unpowered and the sensor does not lose its position information during a power failure, makes the RSM-2800 with its diameter of only 28 mm an extremely compact real **True-Power-On rotary sensor**.

The sensor operates magnetically and thus contactless allowing an extremely long life.

The sensor is able to detect angular positions over 2 to 16 revolutions with a high resolution up to 18 bits.

## Contents

<b>Mechanical Data</b>	3
<b>Output Characteristics</b>	4
<hr/>	
<b>Analog versions</b>	
Technical data	5
Ordering code	6
<hr/>	
<b>Digital versions</b>	
Technical data SSI	7
Technical data SPI	8
Ordering code	9
<hr/>	
<b>Accessories</b>	
M12 connector system	10
Signal processing	11

## Mechanical Data

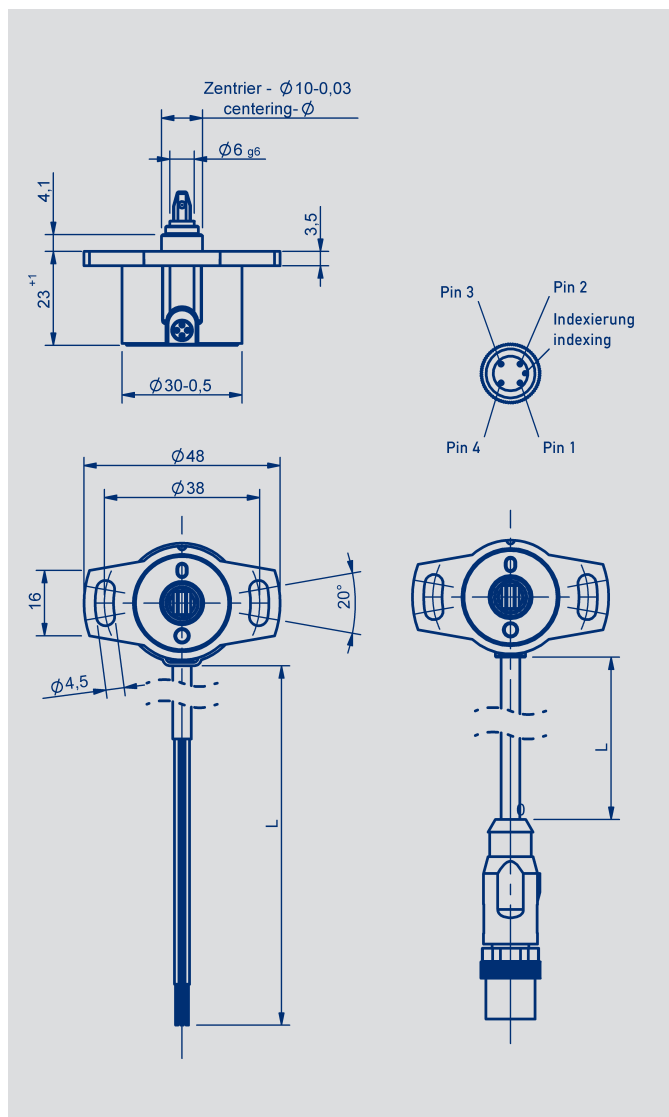

### Description

Housing	High grade, temperature-resistant plastic, PPS-GF40 / SF50
Shaft	Stainless steel, X8CrNiS18-9 1.4305
Bearings	Sintered bronze bushing
Electrical connections	Cable 4 x 0.5 mm <sup>2</sup> , AWG 20, TPE insulated, shielded (voltage / current) Cable 4 x 2 x 0.25 mm <sup>2</sup> , AWG 24, TPE insulated, shielded (SSI) Cable 5 x 0.14 mm <sup>2</sup> , AWG 26, PUR insulated, shielded (SPI) Connector M12x1, 4-pin / 8-pin on cable L = 0,15 m

### Mechanical Data

Dimensions	see dimension drawing	
Mounting	2 screws M4 and washers	
Starting torque of mounting screws	180	Ncm
Mechanical travel	360 continuous	°
Permitted shaft load (axial and radial) static or dynamic force	20	N
Torque	0,15 (IP54), 0,5 (IP65) 1,0 (IP67)	Ncm
Permitted operational speed	800	min-1
Weight	approx. 50	g
Insensitiv to constant magnetic fields	<15	mT
Vibration (IEC 68000-2-6)	5 ... 2000 Amax = 0.75 amax = 20	Hz mm g
Shock (IEC 68000-2-27)	50 (6 ms)	g
Protection class (DIN EN 60529)	IP54 / IP65 / IP67	
Operating temperature	-40 ... +85 (-25 ... +85 with M12 connector) °	
Life	>50 x 10 <sup>6</sup> (mechanically)	movem.

### Shaft designs

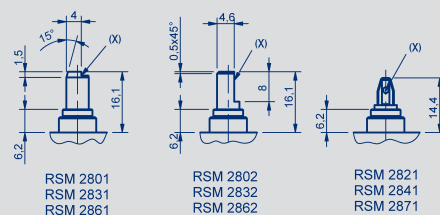

(X) = Wellenmarkierung / shaft marking

Recommended dimensions of driving shaft for RSM-2821 / RSM-2841 and RSM-2871  
Parallel offset < 0.05 mm.

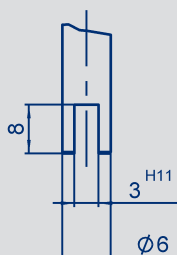

Recommended hole pattern  
2 x  $\varnothing 4.3$  or 2 x M4

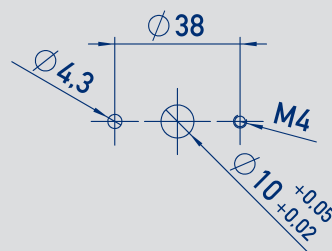

## Output Characteristics

Output signals measurement range 2 ... 14 turns

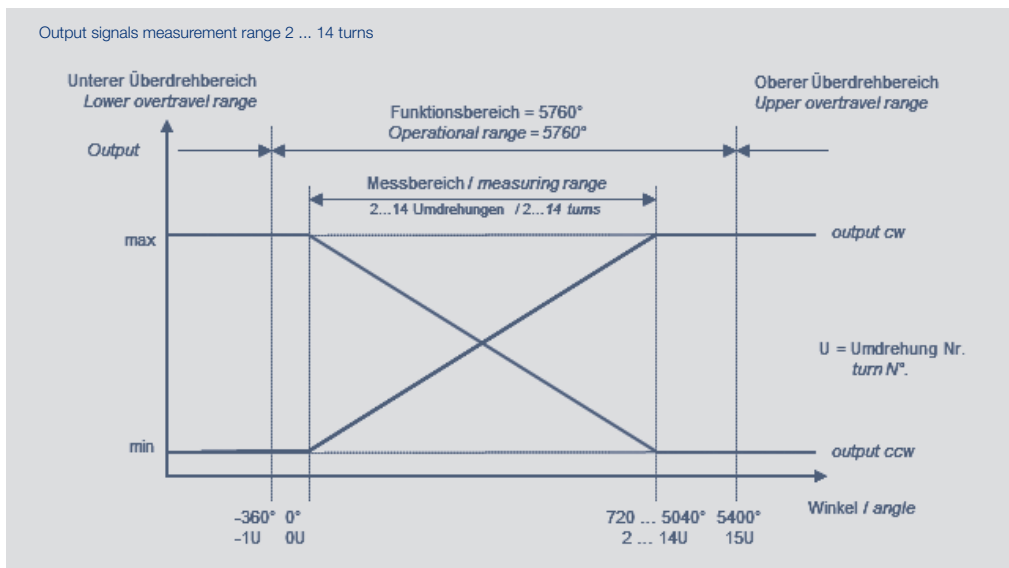

Output signals measurement range 15 ... 16 turns

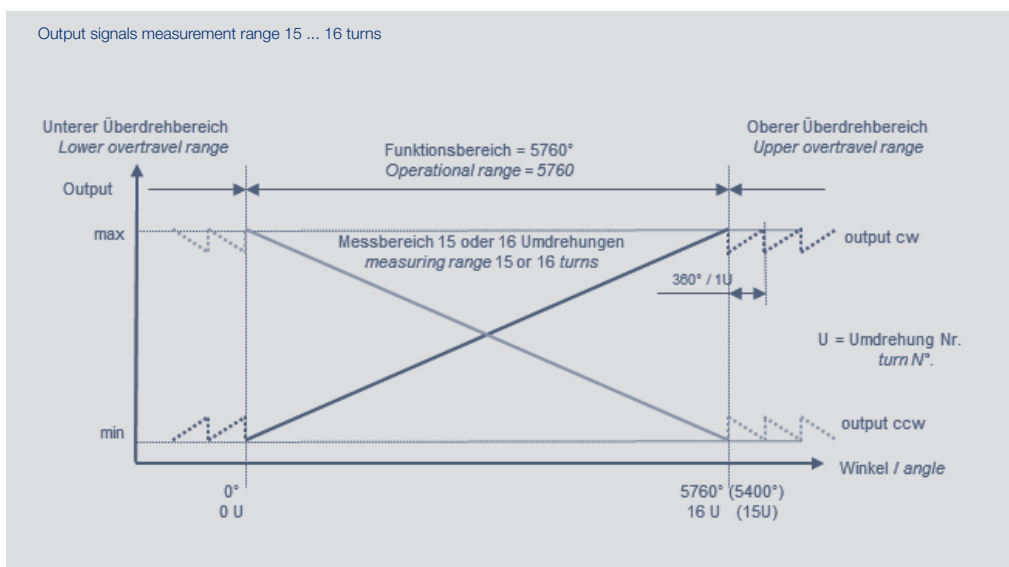

**Technical Data  
Analog Versions  
- Voltage  
- Current**

Type Designations	RSM - 28 _ _ _ _ _ 2 _ _ _ _ _ Ratiometric	RSM - 28 _ _ _ _ _ 11 _ _ _ _ _ Analog voltage	RSM - 28 _ _ _ _ _ 12 _ _ _ _ _ Analog current												
<b>Electrical Data</b>															
Output signal	ratiometric load $\geq 10\text{ k}\Omega$	0.1 ... 10 V load $\geq 10\text{ k}\Omega$	4 ... 20 mA burden $\leq 500\ \Omega$												
Number of channels	1 / 2	1 / 2	1												
Measuring range	0 ... 720° up to 0 ... 5760 (360° steps)			°											
Independent linearity	0.25 ... 0.031 (see table below)			±% FS											
Start-up time	typ. 10			ms											
Response time	max. 2			ms											
Repeatability	$\leq 0.5$			±°											
Hysteresis	$\leq 1$			°											
Temperature error	$\leq 0.15$	$\leq 0.31$	$\leq 0.625$	±% FS											
Supply voltage $U_b$	5 (4.5 ... 5.5)	24 (18 ... 30)	24 (18 ... 30)												
Current consumption (w/o load)	typ. 30			mA											
Reverse voltage	yes, supply lines and outputs														
Short circuit protection	yes (vs. supply voltage and GND)														
Insulation resistance (500 VDC)	$\geq 10$			M $\Omega$											
Cross-section cable	AWG 26, 0.14 (AWG 20, 0.5)*			mm <sup>2</sup>											
<b>Environmental Data</b>															
MTTF (DIN EN ISO 13849-1 parts count method. w/o load)	175 single 175 (per channel, at 2 outputs)	184 single 184 (per channel, at 2 outputs)	186	years years											
Functional safety	If you need assistance in using our products in safety-related systems, please contact us														
EMC compatibility	EN 61000-4-2 electrostatic discharges (ESD) 4 kV, 8 kV EN 61000-4-3 electromagnetic fields 10 V/m EN 61000-4-4 electrical fast transients (burst) 1 kV EN 61000-4-6 conducted disturbances, induced by RF fields 10 V eff. EN 61000-4-8 power frequency magnetic fields 3 A/m EN 55011/EN 55022/A1 radiated disturbances class B														
<b>Linearities</b>															
Measuring range	2	3	4	5	6	7	8	9	10	11	12	13	14	15	16
Linearity typ.	0.250	0.167	0.125	0.100	0.083	0.071	0.063	0.056	0.050	0.045	0.042	0.039	0.036	0.033	0.031
Linearity max.	0.350	0.267	0.225	0.200	0.183	0.171	0.163	0.156	0.150	0.145	0.142	0.138	0.136	0.133	0.131



\*) The cross-sections of the lead wires will be increased to 0.5 mm<sup>2</sup>.  
The changeover is carried out depending on model type and starts from Q1-2016.  
For questions, please call your local distributor or our hotline on +49 711 4489 250.

**Connection assignment**

Signal	Cable code 2 _ _	M12 connector code 501
Supply voltage $U_b$	GN	pin 1
Output 1	WH	pin 2
GND	BN	pin 3
Output 2 / Not assigned	YE	pin 4

Cable shielding connect to GND.

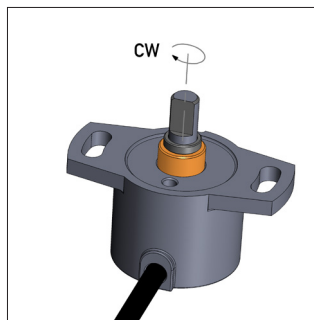

When the shaft marking points towards the cable outlet, the sensor is located on an integer turn position.

## Ordering Code Analog versions

### Ordering specifications

**Preferred types printed in bold:**

- Delivery time up to 25 pcs. within 10 working days
- best low-volume pricing

**Supply voltage Ub**

- 1: 24 V (18 ... 30 V)  
2: 5 V (4.5 ... 5.5 V)

**Output signal - supply voltage = 24 V**

- 1: 0.1 ... 10 V  
2: 4 ... 20 mA

**Output signal - supply voltage = 5 V**

- 1: 0.25 ... 4.75 V ratiometric to supply voltage (5 ... 95 %)  
2: 0.5 ... 4.5 V ratiometric to supply voltage (10 ... 90 %)

**Output characteristics**

- 1: Rising cw  
2: Rising ccw  
3: 2 crossed characteristics, channel 1 rising / channel 2 falling cw  
(only at supply voltage = 5 V or voltage output 0 ... 10 V)  
Other output characteristics on request

**Electrical connection**

- 201: Cable 4-pole, L = 0.5 m, shielded  
202: Cable 4-pole, L = 1 m, shielded  
206: Cable 4-pole, L = 3 m, shielded  
210: Cable 4-pole, L = 5 m, shielded  
220: Cable 4-pole, L = 10 m, shielded  
501: Connector M12, 4-pin, on cable, L = 0.15 m, shielded  
Cable versions and assembled connectors on request

**R S M - 2 8 3 2 - 0 1 0 - 1 1 1 - 2 0 2**

Series

**Mechanical version**

- 2801: 6 mm shaft with marking, IP54\*  
2831: 6 mm, shaft with marking, IP65\*  
2861: 6 mm shaft with marking, IP67\*  
2802: 6 mm shaft with flattening, IP54  
**2832: 6 mm shaft with flattening, IP65**  
2862: 6 mm shaft with flattening, IP67  
2821: push-on coupling, IP54  
**2841: push-on coupling, IP65**  
2871: push-on coupling, IP67  
Other shaft designs on request

**Number of turns for output characteristic**

- 002 = 2 turns up to 016 = 16 turns, increment 1 revolution  
**003, 006, 010, 016**  
Other measuring angles on request

X Revolutions correspond to a measuring angle of X • 360°  
\* Not recommended for new designs

## Technical Data SSI interface

Type Designations	RSM - 28__ - 2__ - 14_ - ___ Supply voltage 24 VDC	RSM - 28__ - 2_ - 24_ - ___ Supply voltage 5 VDC	
<b>Electrical Data</b>			
Protocol	SSI		
Coding	Gray code, binary code		
Monoflop time (tm)	20 ±1		µs
Update rate (internal)	1		kHz
Resolution output signal	16 or 18 over the entire measuring range		Bit
Measuring range	see ordering code		
Absolute linearity	14 revolutions: ≤ 0.036 16 revolutions: ≤ 0.031		± % FS ± % FS
Repeatability	≤ 0.5		± °
Hysteresis	≤ 1		°
Temperature error	≤ 0.1		± % FS
Supply voltage Ub	24 (10 ... 32)	5 (4.5 ... 5.5)	V
Current consumption (w/o load)	typ. 10	typ. 20	mA
Reverse voltage	yes, supply lines and outputs		
Short circuit protection	yes (vs. GND, max. 1 min.)	yes (vs. GND and supply voltage, max. 10 min.)	
Inputs	RS 422 compatible, CLK-lines electrically isolated via optocouplers		
Ohmic load at outputs	≥ 120		Ω
Max. clock rate	100		kHz
Insulation resistance (500 VDC)	≥ 10		MΩ
Cross-section cable	AWG 24, 0.25		mm²
<b>Environmental Data</b>			
MTTF (DIN EN ISO 13849-1 parts count method, w/o load)	173	179	years
Functional safety	If you need assistance in using our products in safety-related systems, please contact us		
EMC compatibility	EN 61000-4-2 electrostatic discharges (ESD) 4 kV, 8 kV EN 61000-4-3 electromagnetic fields 10 V/m EN 61000-4-4 electrical fast transients (Burst) 1 kV EN 61000-4-6 conducted disturbances, induced by RF fields 10 V eff. EN 61000-4-8 Power frequency magnetic fields 3 A/m EN 55016-2-3 radiated disturbances class B		

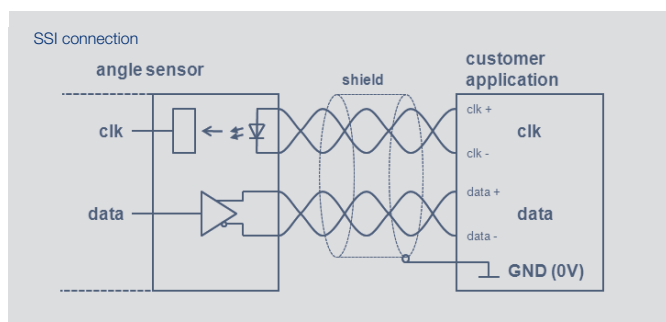
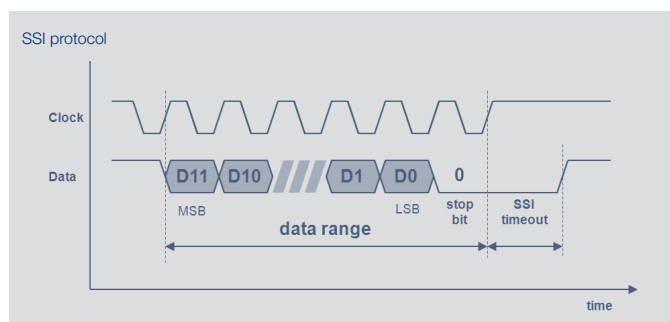

### Connection assignment

Signal	Cable Code 4 __	Stecker M12 Code 531
Supply voltage Ub	WH	pin 1
GND	BN	pin 2
Clock input SSI Clk-	GN	pin 3
Clock input SSI Clk+	YE	pin 4
Signal output SSI Data-	GY	pin 5
Signal output SSI Data+	PK	pin 6
Not assigned	BU	pin 7
Not assigned	RD	pin 8

When the shaft marking points towards the cable outlet, the sensor is located on an integer turn position.

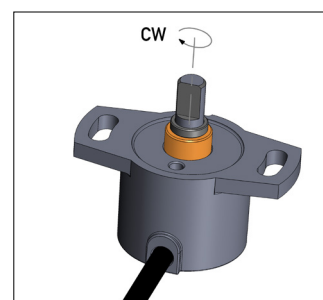

## Technical Data SPI interface

<b>Type Designations</b>	<b>RSM - 28 _ _ - 2 _ _ - 2 8 _ - _ _ _</b> Supply voltage 5 VDC	
<b>Electrical Data</b>		
Protocol	SPI	
Coding	binary code	
Level SCLK, MISO, /SS	TTL level	
Update rate (internal)	1	kHz
Resolution	16 over the entire measuring range	Bit
Measuring range	see ordering code	
Absolute linearity	14 revolutions: $\leq 0.036$ 16 revolutions: $\leq 0.031$	$\pm$ % FS $\pm$ % FS
Repeatability	$\leq 0.5$	$\pm$ °
Hysteresis	$\leq 1$	°
Temperature error	$\leq 0.1$	$\pm$ % FS
Supply voltage $U_b$	5 (4.5 ... 5.5)	V
Current consumption (w/o load)	typ. 25	mA
Reverse voltage	yes, supply lines and outputs	
Short circuit protection	yes (vs. GND and supply voltage)	
Max. clock rate	100	kHz
Insulation resistance (500 VDC)	$\geq 10$	M $\Omega$
Cross-section cable	AWG 26, 0.14	mm <sup>2</sup>
<b>Environmental Data</b>		
MTTF (DIN EN ISO 13849-1 parts count method, w/o load)	193	years
Functional safety	If you need assistance in using our products in safety-related systems, please contact us.	
EMC compatibility	EN 61000-4-2 electrostatic discharges (ESD) 4 kV, 8 kV EN 61000-4-3 electromagnetic fields: 10 V/m EN 61000-4-4 electrical fast transients (Burst) 1 kV EN 61000-4-6 conducted disturbances, induced by RF fields 10 V/m eff. EN 61000-4-8 Power frequency magnetic fields 3 A/m EN 55016-2-3 radiated disturbances class B	

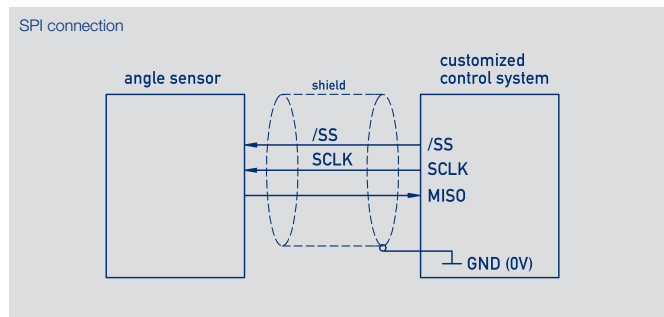
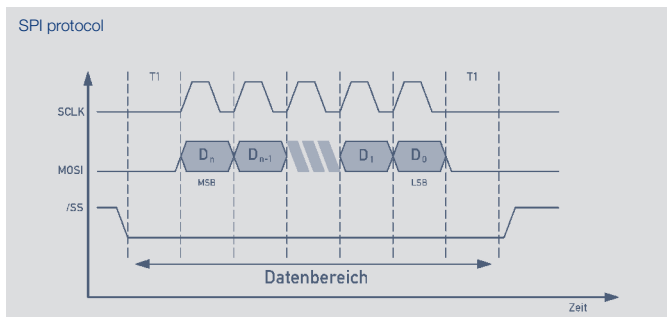

### Connection assignment

Signal	Cable Code 302
Supply voltage $U_b$	GN
GND	BN
MISO	YE
SCLK	GY
/SS (slave select)	WH

When the shaft marking points towards the cable outlet, the sensor is located on an integer turn position.

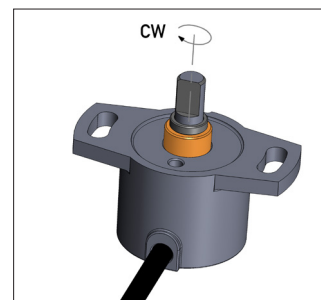



**Ordering Code**  
**Digitale Varianten**  
- SSI  
- SPI

**Ordering specifications**

**Preferred types printed in bold:**

- Delivery time up to 25 pcs. within 10 working days
- Best low volume pricing

**Supply voltage  $U_b$**

- 1:  $U_b = 24\text{ V}$  (10 ... 32 V)**  
**2:  $U_b = 5\text{ V}$  (4.5 ... 5.5 V)**

**Interface parameters for SSI Interface**

- 41: 24 V, SSI 16 bit, Gray code, rising cw**  
42: 24 V, SSI 16 bit, Gray code, rising ccw  
43: 24 V, SSI 25 bit (18 bit data), Gray code, rising cw  
44: 24 V, SSI 25 bit (18 bit data), Gray code, rising ccw  
45: 24 V, SSI 16 bit, binary code, rising cw  
46: 24 V, SSI 16 bit, binary code, rising ccw  
47: 24 V, SSI 25 bit (18 bit data), binary code, rising cw  
48: 24 V, SSI 25 bit (18 bit data), binary code, rising ccw

**Interface parameters for SPI Interface**

- 81: 5 V, SPI 16 bit, binary code, rising cw**  
82: 5 V, SPI 16 bit, binary code, rising ccw

**Electrical connection**

- SSI:**  
432: Cable 8-pole, shielded, L = 1 m  
436: Cable 8-pole, shielded, L = 3 m  
440: Cable 8-pole, shielded, L = 5 m  
450: Cable 8-pole, shielded, L = 10 m  
**531: Connector M12, 8-pin, on cable, L = 0.15m, shielded**  
**SPI**  
302: Cable 5-pole, shielded, L = 1 m  
Cable versions and assembled connectors on request

**R S M - 2 8 3 2 - 2 1 4 - 2 8 1 - 3 0 2**

Series

**Mechanical version**

- 2802: 6 mm-shaft with flattening, IP54  
**2832: 6 mm-shaft with flattening, IP65**  
2862: 6 mm-shaft with flattening, IP67  
2821: push-on coupling, IP54  
**2841: push-on coupling, IP65**  
2871: push-on coupling, IP67  
Other shaft versions on request

Interface  
**2: Digital interface**

**Number of turns for output characteristic**

- 14: 14 turns = 5040°, measuring range controlled**  
16: 16 turns = 5760°, measuring range not controlled

**Accessories**  
Connector system M12

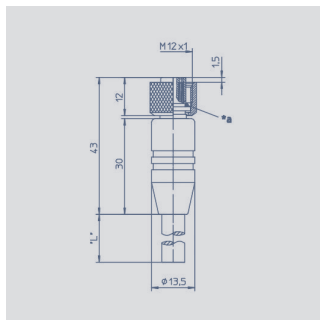
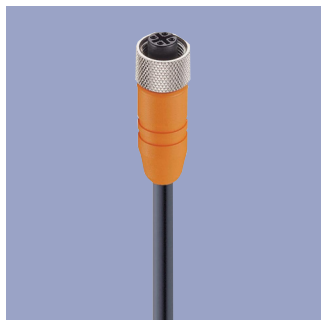

Pin assignment  
1 = brown  
2 = white  
3 = blue  
4 = black

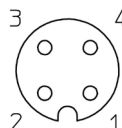

**M12x1 Mating female connector, 4-pin, straight, A-coded, with molded cable, shielded, IP67, open ended**

Connector housing	Plastic PA	
Cable sheath	PUR; Ø = max. 6 mm, -25 °C...+80 °C (moved) -50 °C...+80 °C (fixed)	
Wires	PP, 0.34 mm <sup>2</sup>	
<b>Length</b>	<b>Type</b>	<b>P/N</b>
2 m	EEM 33-32	005600
5 m	EEM 33-62	005609
10 m	EEM 33-97	005650

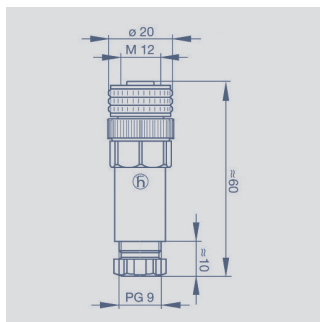

Pin assignment

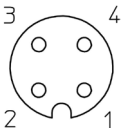

**M12x1 Mating female connector, 4-pin, straight, A-coded, with coupling nut, screw termination, IP67, not shielded**

Connector housing	Plastic PBT	
housings	-25 °C...+90 °C	
For wire gauge	6...8 mm, max. 0.75 mm <sup>2</sup>	
Type	EEM 33-88, P/N 005633	

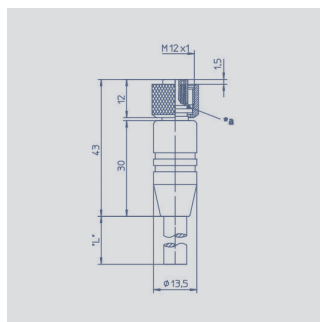
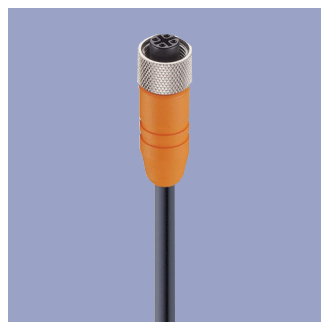

Pin assignment  
1 = white  
2 = brown  
3 = green  
4 = yellow  
5 = grey  
6 = pink  
7 = blue  
8 = red

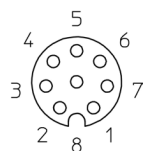

**M12x1 Mating female connector, 8-pin, straight, A-coded, with molded cable, shielded, IP67, open ended**

Connector housing	Plastic PA	
Cable sheath	PUR; Ø = max. 8 mm, -25 °C...+80 °C (moved) -50 °C...+80 °C (fixed)	
Wires	PP, 0.25 mm <sup>2</sup>	
<b>Length</b>	<b>Type</b>	<b>P/N</b>
2 m	EEM 33-86	005629
5 m	EEM 33-90	005635
10 m	EEM 33-92	005637

**Multifunctional  
Measuring Device  
with Display  
Series MAP-4000**

Novotechnik U.S., Inc.  
155 Northboro Road  
Southborough, MA 01772  
Phone 508 485 2244  
Fax 508 485 2430  
info@novotechnik.com  
www.novotechnik.com

© 07/2016  
Subject to changes.

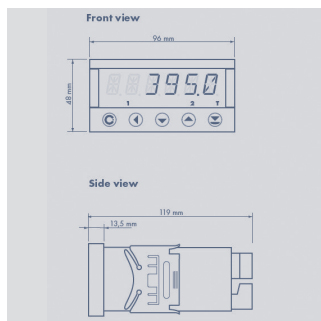

**Special features**

- Supply voltage 10 ... 30 VDC, 80 ... 250 V DC or AC
- high accuracy
- direct connection of potentiometric and standardized signals
- adjustable supply voltage for sensors 5 ... 24 V
- Temperature coefficient 100 ppm/K
- optional RS 232, RS 485, analog output, limited switch
- complete data see separate [data sheet MAP-4000](#)

**Ordering specifications**

**Number comparator relays**

- 0: none
- 2: 2 relays
- 4: 4 relays

**Analog output**

- 0: no analog output
- 1: analog output present

**Interface**

- 0: no interface
- 1: RS 232
- 2: RS 485

**M A P - 4 0 1 0 - 0 0 0 - 1 0 1**

**Display colour**  
1: red

**Data storage (only with interface)**

- 0: not storage
- 1: RTC storage
- 2: FAST storage

Series

**Supply voltage  $U_b$**   
00: 10 ... 30 V AC/DC  
10: 80 ... 250 V AC

**Adjustable supply voltage (5 ... 24 V / max. 1.2 W)**  
1: with supply voltage