

LENGTH- AND ANGLE- MEASURING SYSTEMS MAP 300/400



OPERATING INSTRUCTIONS (44/00)

1	SAFETY INSTRUCTIONS	page	3
1.1	WARNINGS		3
1.2	EMI-INSTALLATION POINTERS		4
1.3	UNIT POINTERS		4
2	FOUNDATIONS		5
2.1	APPLICATION		5
2.2	FUNCTION-DESCRIPTION		5
2.3	SCHEMATIC DIAGRAM		5
2.4	CONNECTING CABLES		6
2.5	FEATURES		6
2.6	OPTIONS		6
3	SETUP MENU		7
3.1	LIMIT VALUE FUNCTION		7
3.2	INPUT FUNCTION		8
3.2.1	Taring function		9
3.2.2	Storage function		10
3.2.3	Blocking functions		10
3.2.4	Peakdetector		11
3.2.5	BCD- or HEX-inquiry		11
3.2.6	Print start		11
3.2.7	Display dark function		11
3.2.8	Closed-circuit current function for outputs		12
3.2.9	Limit value acceptance		12
3.3	INTERFACE FUNCTION (RS232)		12
3.4	MEASURING RANGE		13

3.5	CALIBRATION	14
3.6	ANALOG OUTPUT (OPTION)	15
4	FUNCTION MENU	page 16
4.1	MEASURING RATE	16
4.2	DISPLAY FUNCTION	16
4.3	DECIMAL POINT	17
4.4	TARING VALUE	17
4.5	HYSTERESIS VALUE	17
4.6	TIME / DATE (OPTION)	17
5	LIMIT VALUES	18
5.1	LIMIT VALUE PROGRAMMING	18
5.2	RELAY CONTACT OUTPUT	18
5.3	OPTOCOUPLER OUTPUT	18
6	INFO MENU	19
7	AUXILIARY VOLTAGE OUTPUT	21
8	ERROR MESSAGES	21
9	TECHNICAL DATA	22
10	CONNECTION / OPERATING CONTROLS	24
11	DESCRIPTION IN/OUTPUTS	25

1 SAFETY INSTRUCTIONS

1.1 WARNINGS



- **Operating Instructions**

For a safety operating of this unit you have to read first the operating instructions, the safety instructions and the warnings. During putting into operation you have to observe the succession of the programming and the operating of the unit like

When you are putting the unit into operation you have to look after the succession of the manual. Please follow the instructions for operation and use of the unit in all points. Please keep the manual so that you can look up anything if you have to or an other person can also read it.

- **Personal**

Putting into operation of these measuring systems is only allowed for qualified and instructed personal. Only EMI-qualified personal is allowed to put these units into operation. We will offer on request trainings to the unit techniques and the operating.

- **VDE-Instructions**

During connecting the units you have to observe the instructions of the VDE and the instructions of the professional association for working with electrical units and systems.

- **Employment area**

These units are only designed for operating in industrial applications. As standards DIN EN 50081-2 and DIN EN 50082-2 only allowed these units in industrial area.

- **Supply of power**

Please connect this unit only with the power supply, which is marked on the type sign.

- **Attendance**

Please do not try to open the screw caps. The guarantee is automatically null and void if they are damaged. The unit is only allowed to be repaired by the producer. The user can eventual repairs or rebuilds build only with the permission of the producer through. Before opening the unit remove all connection cables.

- **Water and dampness**

For prevention of fire or dangers by electrifying, you have to safe the unit before rain or dampness. At sites of operations where it is the danger of water, which could penetrate into the front side of the unit you have to fit the flexible protecting cap FSH (IP65). Please do not use the unit near a wash bassin, kitchen sink, washing-machine, swimming pool or a damp room.

- **Acclimatisation**

When you lie down a unit at lower temperatures as they are in the operation room, you have to lie down the unit first for two hours without power. It is possible that water will condense on the electronic and this will be dangerous for persons and it could damage the unit.

- **Penetrating alien elements**

You have to look after that there cannot penetrate liquids or other alien elements like shavings, soot or dust by the unit's openings into the unit.

- **Ventilation**

The unit should be build in so that it could get enough ventilation.

- **Heat effect**

Do not fit the unit near of sources of heat or heat producing loads.

- **Cleaning**

Before cleaning the unit you should remove all connection cables. Please use only a low damp rag. Other cleaning products can only be used after consultation with the producer.

1.2 EMC-INSTALLATION POINTERS

- **Signal cables**

Measuring, signal- or sensor cables, which are connected with the measuring system, must not lie parallel to the power cables. Signal cables have to be screened over the whole length, so also into a steer- or switch cabinet, and the screen connection has to be connected as it is described. The screen connection of signal cables may be only connected one-sided or with reference chassis.

- **Power supply cables**

The feeding of the units (direct voltage or alternating current) has to follow out of the same net, which should be free from interference. Should the occasion arise you have to install a mains filter.

- **Cases**

Metal cases in which the units will be installed have to be connected with reference chassis. The non-fused earthed conductor has to be connected low-resistance.

- **Distances**

Around the unit there may be cables that carry a current only in a distance of minimum 10cm. Radio installations or radio telephones should have a distance from minimum 2m to the unit. Interferencing ISM units or switching inductive load like conductors, magnetic rectifiers or motors have to be suppressed from radio noise (RC- or varistor wiring) and should have a distance from 20cm.

1.3 UNIT POINTERS

- **RS232-Interface**

You have to look after, that the RS232-interface from the measuring input and the optional analogous output are not galvanically isolated.

- **Auxiliary voltage output on DC-supply**

At units with 24V-supply (.8) the supply will be connected intern with the auxiliary voltage output. By this the supply input and the auxiliary voltage output have the same reference potential. You have to look after, that the auxiliary voltage output is not short-circuit-proof. If required, you should assign for an extern overload protection.

- **Auxiliary voltage output on AC-supply**

You have to look after, that the auxiliary voltage output is not short-circuit-proof. An overload by short-circuit leads to the responding of the overload protection of the intern transformer, which will switch off. If required you should assign for an extern overload protection.

2 FOUNDATIONS

2.1 APPLICATION

This series of measuring systems are used to display and monitor length and angle values. The main applications are machine and test equipments.

2.2 FUNCTION

The units MAP 300/400 are microprocessor controled panel-mounting instruments with 3 3/4- to 4 3/4-digit display. The displayed reading can be programmed for the required measuring range. Four independent limit value comparators monitor continuously for overshoot and undershoot of the programmed limits. The serial interface render the connection to a printer. Measurement value and comparator state can be controlled additional with PC or PLC. With the four optoisolated logic inputs many different functions are controlable with external signals.

2.3 SCHEMATIC DIAGRAM

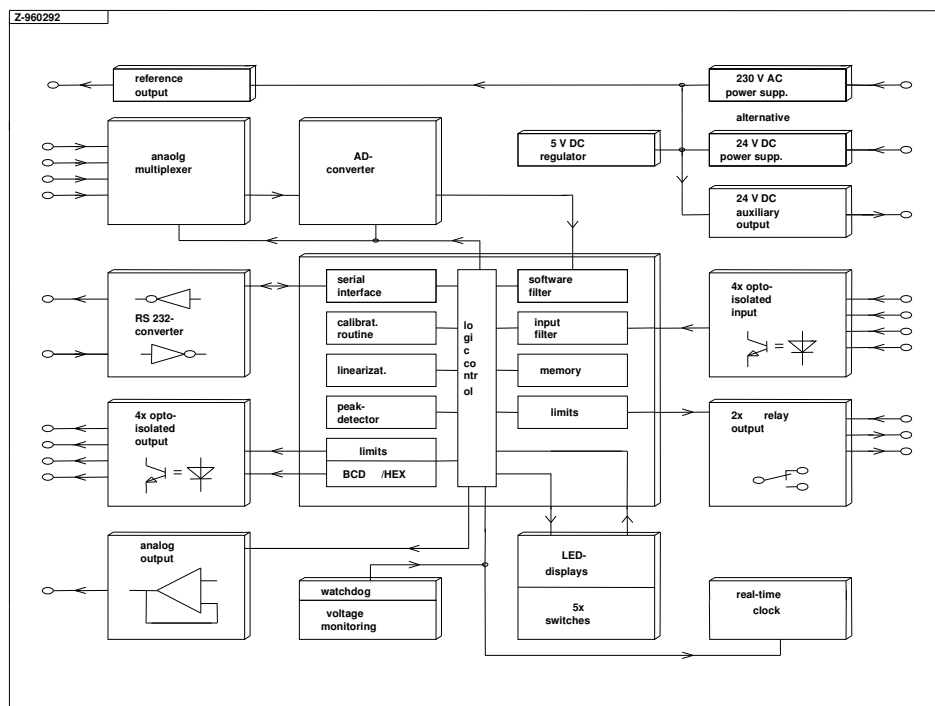

2.4 CONNECTING CABLES

All interfaces, for the measurement input, auxiliary output, logic in-/outputs, serial interface RS232 and the optional analog output are accessible on the rear side connectors. The connecting cables for sensor, analog output and RS 232 interface must be shielded. The shield must be connected to the corresponding terminal (see 10 CONNECTION). It is not allowed to connect the shield at the other cable end to any potential, because that generates a disturbing cable loop. This prevents the optimal function of the unit.

It is not allowed to lay the power and control cables of the unit in the near of power plants, electric welding cables or supply cables for inductive components like motors, magnets, frequency transformers etc.

2.5 FEATURES

The measurement systems have different features. Therefore the service of the units is naturally a little bit different. E.g. units without limit value comparators have no programmable functions like „LIMIT VALUE FUNCTION“ or „LIMIT VALUE PROGRAMMING“. In special chapters that is additional noted.

The following table shows the different features:

feature	MAP 444	MAP 344	MAP 342	MAP 340	MAP 334	MAP 332	MAP 330
display range	-9999/40000	-9999/20000	-9999/20000	-9999/20000	-4000/4000	-2000/2000	-2000/2000
accuracy	0,01%	0,01%	0,01%	0,01%	0,03%	0,03%	0,03%
measuring rate, max.	8/s	16/s	16/s	16/s	32/s	16/s	16/s
limit values	4	4	2	-	4	2	-
relay outputs	2	2	2	-	2	2	-
opto outputs	4	4	-	-	4	-	-
control input 1:	progr.*	progr.*	taring (static)	taring (static)	progr.*	taring (static)	taring (static)
control input 2:	progr.*	progr.*	hold	hold	progr.*	hold	hold
control input 3:	progr.*	progr.*	taring reset	taring reset	progr.*	taring reset	taring reset
control input 4:	progr.*	progr.*	taring (dyna.)	taring (dyna.)	progr.*	taring (dyna.)	taring (dyna.)
RS232 interface	yes	yes	no	no	yes	yes	no
BCD/HEX interface	yes	yes	no	no	yes	yes	no
realtime-clock	option	option	no	no	option	option	option
analog output	option	option	option	option	option	option	option
calibr.: teach-in	yes	yes	yes	yes	yes	yes	yes
calibr.: standard	yes	yes	yes	yes	yes	yes	yes

2.6 OPTIONS

- Power supply 110 V AC 50/60 Hz; 24 V DC 6 W
- Realtime-clock (date / time)
- Analog output 0-10 V DC or 0/4-20 mA DC
- Flexible cover FSH (IP65)

3 SETUP MENU

Via the SETUP menu, all of the elementary measuring and control functions of the unit are defined and calibration of the measuring range/sensors is carried out. These parameters, which are always in connection with superior controls, are always programmed first with initial operation.

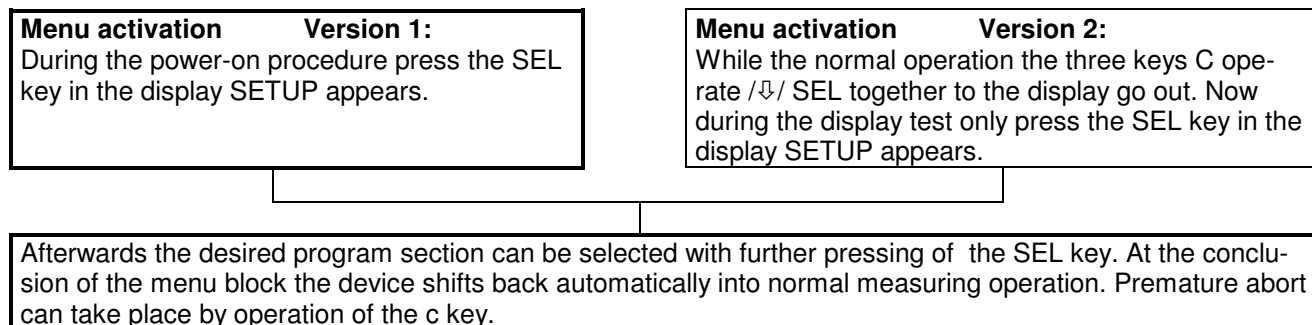

SETUP MENU:

function display (see OPERATING CONTROLS)

- [1] limit value function
- [2] input function
- [3] interface function
- [4] measuring range
- [5] calibration BEGIN value
- [6] calibration END value
- [7] analog output function (option)
- [8] analog output start value (option)
- [9] analog output stop value (option)

3.1 LIMIT VALUE FUNCTION [1]

In this menu, the switching function (MIN/MAX), the number of limiting value outputs and the programming block of single limiting values can be selected. Furthermore, it is possible to define whether the limiting value setting range is to be possible over the entire numerical range or only over the calibrated range (by defining the BEGIN- and END-values).

unit	MAP 334/344/444	MAP 332/342	MAP 330/340
limit values	4	2	no

- Limit value function:**
- MAX-function (H/h):**
output is switched when the limiting value is exceeded.
 - MIN-function (L/L):**
output is switched when the limiting value is undershot.

After calling this program routine [1], the measured value is display to set the limiting value functions L, H, L and h as well as the number of limiting values used 0...4 is displayed.

The number of limiting values used flashes and can be changed between 0 and 4 as well as 1. and 4. by pressing the $\uparrow\downarrow$ - keys. The numerical display with a point means that the limiting value setting range is only possible within the calibration range. The setting possibility of the limiting value number is only beneficial if e.g. generally only 2 limiting values are needed.

To change the limiting value function of an output, the SP>-key is to be pressed until the desired position flashes. After that, it is possible to changeover between L (MIN) and H (MAX) by pressing the $\uparrow\downarrow$ - keys.

- L** switching function MIN, limiting value not program-protected
- H** switching function MAX, limiting value not program-protected
- L** switching function MIN, limiting value program-protected
- h** switching function MAX, limiting value program-protected

The limiting value function is set at "not program-protected" as standard (L/H). With this, all of the limiting values are firstly changeable. If needed, the limiting value function of individual limiting values can be changed afterwards to "program-protected".

Example (series MAP 334/344/444):

- L H h 4.** Four limiting values (setting range only within the calibration range)
 1. limiting value: (**L**) MIN-function, program-protected
 2. limiting value: (**L**) MIN-function, not program-protected
 3. limiting value: (**H**) MAX-function, not program-protected
 4. limiting value: (**h**) MAX-function, program-protected

3.2 INPUT FUNCTION [2]

All control inputs are controllable via 24 V signals. If only switching contacts are used externally, these can be supplied by the 24 V auxiliary voltage output.

MAP 334/344/444:	MAP 342/340/332/330:
The 4 opto-isolated control inputs are preprogrammed in the factory for the most common four standard functions. However, these can be optionally changed (see below).	The 4 opto-isolated control inputs are defined at the factory for the four standard functions and can not be changed.
	Fixed input functions: IN1: taring function (static) IN2: storage function f. display + comparator IN3: taring function reset IN4: taring function (dynamic)

series MAP 334/344/444: standard functions default value of the inputs IN1-4: (display q 2 3 6)

input	display	function
IN1	q	taring function (dynamic)
IN2	2	taring function reset
IN3	3	storage function for: display + comparator
IN4	6	programming block

If required, another function can be selected for each control input. This allows the user to optimally use the external controllable functions.

Selection possibilities of the input functions for all inputs:

display	function	display	function
1	taring function (static) notice the detailed description !	c	BCD-inquiry
2	taring function reset	d	HEX-inquiry
3	storage function: display + com- parator (Hold)	E	print start, measurement value + dimension + comparator (date/time)
4	storage function: comparator	F	display dark function
5	storage function: display	G	closed-circuit output function
6	programming block	H, J, L	print start, progr. text (16 signs)
7	SEL-key block	N	limit value acceptance
8	keyboard block	o	print start: like „E“, but continuous
9	peakdetector: positiv	P	print start: like „E“, but with <CR><LF>
A	peakdetector: negativ	q	taring function (dynamic)
b	peakdetector: difference	-	no function

After calling up program routine [2], the control inputs can be selected by pressing the SP>-key. The position, which is to be changed, flashes. The input functions can be changed by pressing the ↑↓-keys.

Example: display q E 9 A

input	display	function
IN1	q	taring function (dynamic)
IN2	E	print start, measurement value
IN3	9	peakdetector: positiv
IN4	A	peakdetector: negativ

3.2.1 Taring function

The taring function resets the display value at an optional position and can be externally controlled. After activation, only the deviation from the stored taring value is displayed. The taring function can also be reset externally, if a control input is programmed for the function "taring function reset". In the FUNC menu, the taring value can be additionally set to zero or any optional value.

a) Taring function (dynamic): Input function „q“ > New function ! <

The taring value is stored in the internal dynamic RAM. The taring value is active until the supply voltage is connected. After a power fail the taring value is reset to zero. It is recommended to use this function because there is no limitation on storage cycles.

b) Taring function (static): Input function „1“ > Important ! <

The taring value is stored in the internal static EEPROM. Do not use this function for frequently taring cycles. Use this function only for rare cycles, when it is absolutely necessary to protect the actual taring value against power fails. At frequently storage cycles it is possible that storage errors will affect because of the limited and unknown storage capacity of the internal EEPROM-circuit. Data failures detected with an error message (F11) are not a part of the warranty!

3.2.2 Storage functions

The storage function can cause the freezing of the current display value and/or of the comparator state and can also be controlled externally. Three different storage functions can be selected:

- **Storage function: display + comparator (hold)**

During operation, measured value changes do not have any influence on the display value and the switching state of the limiting value comparators.

- **Storage function: display**

During operation, the measured value changes do not have any influence on the display value. Monitoring of the limiting values, however, is still carried out.

- **Storage function: comparator**

During operation, the measured value changes only influence the display value. Monitoring of the limiting values is interrupted and the current switching state of the comparators are frozen.

Special features with BCD- or HEX-inquiry:

With BCD- or HEX-inquiry, the storage function for display and comparators is to be activated for each new reading of the measured value (for this, see the detailed interface description).

3.2.3 Blocking functions

- **Programming block:**

The programming blocking, which can be controlled externally, secures the stored data against unauthorized or unintentional changes. During operation, the data can only be displayed, however, not changed. If a change is attempted, an error message (E24) is also shown in the display.

- **Keyboard block:**

The keyboard blocking, which can be controlled externally, prevents any of the operating possibilities from being carried out via the keys of the unit on the front panel. During operation, an error message (E25) is given off if the keys are operated.

- **SEL-key block:**

The SEL-key blocking, which can be controlled externally, prevents any of the operating possibilities of the SEL-key on the front panel. During operation, the limiting values can therefore only be displayed or changed. If the SEL-key is pressed, an error message (E23) is given off.

3.2.4 Peakdetector

The peak value memory, which can be controlled externally, allows for the registration of maximum, minimum and differential values. During operation, the maximum, minimum or differential value is stored and displayed and the limiting value is supervised independently from the selected function positive, negative or difference. Only after resetting of the activation, is the current measured value displayed and the stored peak value erased.

3.2.5 BCD- or HEX-inquiry

For further processing of the displayed value in an PLC, it can also be output in BCD- or HEX- format via the 4 opto-isolated outputs. For this, a control input must be programmed for the „storage function: display + comparator“ and another must be programmed for the function „BCD inquiry“ or „HEX inquiry“.

With activation of the storage input, the current displayed value and/or the comparator state is frozen and the output register is loaded. Activation may only be reset after the data is accepted, since the register is reloaded with every new activation.

From the first 0->1-edge at the input "BCD- or HEX-inquiry", the stored comparator state is applied at the 4 outputs. After the first positive edge, the sign (0 = positive, 1 = negative) is given out. After that, with every further positive edge, the single decimal digits (always 5 digits) are given out beginning with the highest value digit. A more detailed description of the BCD/HEX interface can be taken from the detailed interface description.

3.2.6 Print start

With the use of the serial RS 232 interface, it is possible to output the data via a printer by activating an input programmed as a „Print start“ input.

Print start, measured value:

The measured value is output along with the unit of measure and the comparator state.

Print start, programmable texts (16 characters):

Three programmable texts with a maximum of 16 characters are output (for this, see INTERFACE FUNCTION).

3.2.7 Display dark function

With this function, the complete display including the limiting value LED's can be darkened during the normal function of the measuring system. All of the other functions of the measuring system are not influenced by this darkening circuit.

3.2.8 Closed-circuit current function for outputs

The closed-circuit current function is predominantly used in technical safety systems. The switching states of the 4 outputs are inverted with activation of the rest current function. This means that one output is switched to the rest current state with activation, which corresponds to a voltage failure of the unit. The rest current function acts on all 4 limiting value outputs whereby, however, only the two relay outputs for safety-relevant circuits should be used.

3.2.9 Limit value acceptance

With activation of a logic input, which is programmed for the function „Limit value acceptance“, the current measured value is accepted as a limiting value. With this, a change of the limiting value is carried out according to the logic input number, e.g. with logic input IN3, the limiting value SP3 is accepted. In this way, all 4 limiting values can be stored via external control.

3.3 INTERFACE FUNCTION (RS232) [3]

series MAP 334/344/444:

With the interface function, what peripheral unit is connected to the serial interface and what data protocol is being used is determined. If no peripheral unit is connected to the serial interface, the setting of the interface function is of no importance.

After calling up the program routine [3], selection of the peripheral unit (A, b or C flashes) can be carried out by pressing the $\uparrow\downarrow$ -keys. After that, the desired data protocol must be selected by pressing the SP>-key once. Using the $\uparrow\downarrow$ -keys, the number of the data protocol can be changed.

device	display	printout with dimension	device	display	printout with dimension
printer	A000	no dimension	printer	A001	mm
	A002	cm		A003	m
	A004	Grd		A005	°
	A006	mbar		A007	bar
	A008	Pa		A009	l/h
	A010	g		A011	kg
	A012	t		A013	N
	A014	Ncm		A015	Nm
	A016	°C		A017	°F
	A018	K		A019	mV
	A020	V		A021	kV
	A022	mA		A023	A
	A024	kA		A025	mW

A026	W	A027	kW
A028	VA	A029	Vol %
A030	% AW	A031	kN
A099	progr. value (8 signs)		

Additional peripheral devices:

device	display	function
PC/PLC	b100	distant reading or distant control PC/ PLC
FAZ47	C200	slave indicator FAZ 47

Programmable dimension / text:

The unit of measure with a maximum of 8 characters and the three texts with a maximum of 16 characters can be programmed via the interface. For more information about this, see the interface description.

Data format:

The data format of the interface is permanently set and can not be changed. Please take the exact data protocols from the detailed interface description.

9600 bps / 1 Start / 8 Databit / 2 Stopbit / No parity check

3.4 MEASURING RANGE [4]

In this program routine, the desired measuring range is programmed. The connection of the signal source or the sensor must also be carried out according to this setting.

Measuring ranges, learning (teach-in):

With these measuring ranges, calibration is carried out with reading of two different measured values and allocated to different displayed values.

display	measuring range	calibration
100	potentiometer	teach-in
200 / 270	0-10V DC	
201	1-6V DC	
220	0-20mA DC	
221	4-20mA DC	

Measuring ranges, not learning (standard values):

With these measuring ranges, calibration is carried out without the reading in of measured values. For allocation of the desired display values, the unit always uses the standard values for the BEGIN value and END value of the measuring range that was stored in the memory at the factory. Potentiometers do not have a standard output and can therefore only be calibrated using the teach-in method.

display	measuring range	measuring range: BEGIN value	measuring range: END value	calibration
300 / 370	0-10V DC	0V	10V	standard
301	1-6V DC	1V	6V	
320	0-20mA DC	0mA	20mA	
321	4-20mA DC	4mA	20mA	

3.5 CALIBRATION

Calibration of the measuring system is carried out in different ways depending on the selected type of measuring range. It is only necessary once or after selection of a new measuring range or possibly after the exchange of a potentiometric sensor.

3.5.1 Calibration of learning measuring ranges (teach-in)

With these measuring ranges, the measuring signal is applied during the calibration of sensors or a calibrator.

Calibration routine:

For calibration, two different measured values are allocated to different displayed values. The display values are allocated by the user following automatic reading of the current measured value. After BEGIN and END value programming is carried out, calibration is completed.

BEGIN value programming [5]

After selecting the program routine [5], the sensor to be calibrated must firstly be brought to a value or position, which is defined as the BEGIN value. To program the BEGIN value, press down the SP>-key and additionally press the \uparrow -key. After that, the current measured value is automatically read (display 3-2-1) and the possibility to change the value is released. After that, a display value corresponding to the current measured value must be set using the $\uparrow\downarrow$ -keys.

END value programming [6]

After selecting the program routine [6], the sensor to be calibrated must firstly be brought to a value or position, which is defined as the END value. To program the END value, press down the SP>-key and additionally press the \uparrow -key. After that, the current measured value is automatically read (display 3-2-1) and the possibility to change the value is released. After that, a display value corresponding to the current measured value must be set using the $\uparrow\downarrow$ -keys.

3.5.2 Calibration of not learning measuring ranges (standard values)

With these measuring ranges, the initial data of a sensor is known, however, it can not be simulated for calibration.

Calibration routine:

To carry out calibration, the start of the measuring range and the stop of the measuring range (see section „MEASURING RANGE“) are allocated to two different display values. After BEGIN and END value programming is carried out, calibration is completed.

Example: Measuring range 0 - 10 V DC: BEGIN value is 0 V, END value is +10 V
 Measuring range 4 - 20 mA DC: BEGIN value is 4 mA, END value is 20 mA

BEGIN value programming [5]

After selecting the program routine [5], the BEGIN value must be defined. To program the BEGIN value, press down the SP>-key and additionally press the \uparrow -key. Only then is the possibility to carry out changes released. After that, the desired display value must be set using the $\uparrow\downarrow$ -keys.

END value programming [6]

After selecting the program routine [6], the END value must be defined. To program the END value, press down the SP>-key and additionally press the \uparrow -key. Only then is the possibility to carry out changes released. After that, the desired display value must be set using the $\uparrow\downarrow$ -keys.

3.6 ANALOG OUTPUT

3.6.1 ANALOG OUTPUT FUNCTION (OPTION) 7

The optional analog output (DA) allows for the connection of external measuring, control and recording units to the measuring system. After calling up the program routine [7], the function and the output quantity of the analogue output is shown in the measured value display.

The function (A or P) flashes and can be changed by pressing the $\uparrow\downarrow$ -keys. To change the output quantity (only possible with 0/4-20 mA), the SP>-key is to be pressed once and then the desired value can be set using the $\uparrow\downarrow$ -keys.

Functions:

- Px** Analog signal corresponds to the stored peak value with activated peak value memory. If the input is not activated, the analog signal corresponds to the current measured value (standard setting).
- Ax** Analog signal always corresponds to the current measured value.

Output quantities:

- x5** Analog output 0 - 10 V DC
- x8** Analog output 0 - 20 mA DC

x9 Analog output 4 - 20 mA DC

Important!

The analog output is a part of the analog component of the measuring system and is therefore is at the same potential as the measuring input.

3.6.2 ANALOG OUTPUT START VALUE (OPTION) [8]

The analog start value fixes the display value, with which the analogue output should deliver a 0 % output signal. The value can be changed using the $\uparrow\downarrow$ -keys.

3.6.2 ANALOG OUTPUT STOP VALUE (OPTION) [9]

The analogue stop value fixes the display value, with which the analogue output should deliver a 100 % output signal. The value can be changed using the $\uparrow\downarrow$ -keys.

4 FUNCTION MENU

With the FUNCTIONS-MENU (Operation menu) it's possible to programm all functions which have to be changed more times at the normal measurement operation. This functions have to be programmed at the first starting time after the SETUP-MENU.

MENU ACTIVATING

Press in the normal measurement operation the SEL-key for five seconds till the display shows FUNC. With additional pressing of SEL-key the different function routines are selectable. For break off press C-key.

FUNCTION MENU:

function display

- [A]** measuring rate
- [b]** display function
- [C]** decimal point
- [d]** taring value
- [E]** hysteresis value
- [F]** realtime-clock (option)

4.1 MEASURING RATE [A]

The measuring rate programmes the speed of measurement display and limit value control. The number is adjustable with the $\uparrow\downarrow$ -keys.

Measuring rates: 1 / 2 / 4 / 8 cycles per second

4.2 DISPLAY FUNCTION [b]

In this routine the the function of the display with/without leading zeros and the function of the last digit is programmable. For changing between the two modes press SP>-key, for changing the value press $\uparrow\downarrow$ -keys.

Adjustment of display with/without leading zeros: left side of display

F0 leading zeros YES **F_** leading zeros NO

Adjustment of the function of the last digit (LSD): right side of display

01 display in 1-steps 1, 2, 3
05 display in 5-steps 0, 5, 0
10 display in 10-steps 00, 10, 20

4.3 DECIMAL POINT [C]

The decimal point of the measurement display can be adjusted by pressing SP>-key on every place. i.ex.: **-.-.-.-.-**

4.4 TARING VALUE [d]

The taring value of the measurement display is adjustable over the hole measurement range by pressing $\uparrow\downarrow$ -keys. This routine is normally used to reset the taring value to zero, when the value is programmed on a undefined value by external logic control. The default value is 0000. The frontside LED „taring“ “T” is activated when the taring value is not zero.

4.5 HYSTERESIS VALUE [E]

In this routine the hysteresis value for all four limits is adjustable by pressing the $\uparrow\downarrow$ -keys. A hysteresis value is necessary when an unstable measurement signal triggers moretimes the limit value outputs. The default value is 0000.

4.6 TIME / DATE [F]

In this routine the the optional realtime-clock is adjustable. Time and date are additional outputed on a measurement printout. The realtime-clock can be programmed and readed by the serial interface too.

Adjust of time / date:

After calling this program routine [F], the displayed value can be switched between minute, hour, day, month and year by the SP>-key. For value adjust use the $\uparrow\downarrow$ -keys.

function	minute	hour	day	month	year
display	II - xx	ho - xx	dA - xx	Io - xx	YE - xx

5 LIMIT VALUES

MAP 334/344/444	MAP 332/342	MAP 330/340
The devices have four independent limit value comparators. The function MIN- or MAX-control is programmed by the limit value function. For applications with less then 4 limits the number is programmable from 0 to 4. Standardly the device have for all limits optocoupler outputs and additional relay outputs (two-way) for the limits 1 and 2.	The devices have two independent limit value comparators. The function MIN- or MAX-control is programmed by the limit value function. For applications with less then 2 limits the number is programmable from 0 to 2. Standardly the device have for both limits relay outputs (two-way).	The devices have no limit value comparators.

5.1 LIMIT VALUE PROGRAMMING

By pressing the SP>-key the preferred limit value is selectable (LED blinks). The function display shows additional the limit value function L (MIN) and H (MAX) of the selected number. For changing the limit value press the SP>-key and additional the \uparrow -key or \downarrow -key. All limits which are programmed with the limit value function to state „not adjustable“ are not displayed. So it's possible that 4 limits are activ (3 controls only in the background) but only one limit is adjustable for the user.

5.2 RELAY CONTACT OUTPUT

The two relay outputs (two-way) belong to the limit values 1 + 2.

5.3 OPTOCOUPLER OUTPUT

The four optocoupler outputs belong to the limit values 1...4. If the option realtime-clock is included only limit values 3 and 4. This outputs are not resistant against short circuits and have an additional diode against confusing the poles.

At BCD/HEX-value readout the actual displayed value is transferred out with this outputs 1...4 too. Then the OUT 4 is the MSB and OUT1 the LSB. More about BCD- or HEX-interface see the detailed interface manual. If the option realtime-clock is included BCD- or HEX-output is not possible.

6 INFO MENU

The INFO-MENU is not necessary for the normal operation of the device but there are additional important functions for the documentation of device parameters and test functions available.

MENU ACTIVATING

Press in the normal measurement operation the SEL-key for five seconds till the display shows FUNC. After that press the SP>-key to switch to display INFO. With additional pressing of SEL-key the different function routines are selectable. For break off press C-key.

function display

[0.] configuration

In this routine the manufacture configuration is displayed. This configuration shows informations about the hardware and options.

[1.] software - version

This routine shows the used software-version.

[2.] serial number

This routine shows the serial number of the device.

[3.] limit value function

In this routine the limit value function, the programmed number of activated limits and the function of the limit value adjustment range are displayed.

[4.] input function

This routine shows the input functions of the 4 logic inputs.

[5.] interface function

This routine shows the interface functions of the RS 232-interface.

[6.] measuring range

This routine shows the measuring range.

[7.] measuring rate

This routine shows the measuring rate.

[8.] display function

This routine shows the display function.

[9.] decimal point

This routine shows placement of the decimal point.

[A.] taring value

This routine shows the actual taring value.

[b.] hysteresis value

This routine shows the actual hysteresis value.

[C.] interface test

In this routine the function of the RS 232-interface can be tested. When the TXD and RXD are open the display shows „OPEN“. When TXD and RXD are closed together the display shows „CLOSE“, then the interface is ok. Errors are displayed with „Error“.

[d.] measurement value in %

In this routine the actual measurement value in % is displayed. This function is very helpfull for adjustment of angle sensors which have no mechanical stop.

[E.] AD-value actual

This routine shows the actual AD-value.

[F.] AD-BEGIN value

This routine shows the stored AD-value for BEGIN.

[G.] AD-END value

This routine shows the stored AD-value for END.

[h.] calibration BEGIN value

This routine shows the programmed value for BEGIN.

[J.] calibration END value

This routine shows the programmed value for END.

[L.] input test

In this routine the function of the logic inputs can be tested.

i.ex. 1101 input 1,2 and 4 „ON“. Input 3 „OFF“.

[N.] output test

In this routine the function of the four outputs can be tested.

With the SP>-key the output is selectable (LED 1...4 blinks). With the $\uparrow\downarrow$ -keys the status can be changed.

i.ex. 1101 output 1,2 and 4 „ON“. Output 3 „OFF“.

[o.] parameter printout

In this routine the complete parameter printout can be activated for documentation or diagnostic. With the $\uparrow\downarrow$ -keys the status OFF and ON is selectable. The display returns automatically to OFF when all parameters are printed. For break press C-key.

OPTION: Following routines are only optional available.

[P.] analog output function

This routine shows the analog output function.

[q.] analog output start value

This routine shows the analog output start value (0%).

[r.] analog output stop value

This routine shows the analog output stop value (100%).

[T.] analog output test

In this routine the function of analog output, depend on the used function 0-10 V DC, 0-20 mA or 4-20 mA can be tested. The output signal can be changed from 0-100% by pressing $\uparrow\downarrow$ -keys.

[U.] time / date

This routine shows the actual time and date. With the SP>-key the displayed value is selectable between minute/hour/day/month/year.

7 AUXILIARY VOLTAGE OUTPUT

The logic inputs can be controlled with 24V logic signals. For smaller machines which have no additional 24V auxiliary supply, the integrated 24V auxiliary output can be used to control the logic inputs.

The auxiliary output is not stabilized and do not accept short circuits. The output can be used to supply active sensors with maximum 70 mA too.

8 ERROR MESSAGES

Errors occurring during operation of the measuring system are displayed directly. Some errors have to be quited by pressing any key.

- E 21** calibration: BEGIN and END value are first adjustable after pressing SP>- and ↑-key.
- E 22** taring or taring reset not possible because the AD-value overflow.
- E 23** at pressing SEL-key and activated SEL-block.
- E 24** at programming attempt and activated programming block.
- E 25** at pressing any key and activated keyboard block.
- E 26** AD-overflow at calibration attempt.
- E 30** at activating of an optional input function which is not included.
- E 4x/** data not plausible
- E 5x**
- E 41** - limit values
 - E 42** - input function
 - E 43** - interface function
 - E 44** - measurement rate
 - E 45** - display function
 - E 46** - decimal point
 - E 47** - taring value
 - E 48** - hysteresis value
 - E 49** - device typ
 - E 50** - analog output
- F xx** systeminternal error
- EEEE** continuous, negativ display overflow (math.)
- EEEE** flashes, negativer measurement overflow (AD-converter)
- EEEEE** continuous, positiv display overflow (math.)
- EEEEE** flashes, positiv measurement overflow (AD-converter)

9 TECHNICAL DATA

- power supply:** 230 V AC (+/-10%), 50/60 Hz, 8 VA
optional 110 V AC (+/-10%), 50/60 Hz, 8 VA
optional 24 V DC, 8 W (20...30 V) isolated, isolation: 100 V DC
- display:** 5-digit LED measurement display, height 14mm
1-digit LED function display, height 7mm
- measurement rate:**
- | | | |
|--------------|---------------|--------------------------|
| MAP 330/332: | 1/2/4/8/16 | per second, programmable |
| MAP 340/342: | 1/2/4/8/16 | per second, programmable |
| MAP 334: | 1/2/4/8/16/32 | per second, programmable |
| MAP 344: | 1/2/4/8/16 | per second, programmable |
| MAP 444: | 1/2/4/8 | per second, programmable |
- resolution:**
- | | |
|--------------|-------------------------------|
| MAP 330/332: | typ. 2000 digit (pos. range) |
| MAP 340/342: | typ. 15000 digit (pos. range) |
| MAP 334: | typ. 4000 digit (pos. range) |
| MAP 344: | typ. 15000 digit (pos. range) |

	MAP 444:	typ. 40000 digit (pos. range)
indicated values:	MAP 330/332:	-2000 / 2000
	MAP 340/342:	-9999 / 20000
	MAP 334:	-4000 / 4000
	MAP 344:	-9999 / 20000
	MAP 444:	-9999 / 40000
accuracy:	MAP 330/332:	typ. 0.05 %, +/-1 digit
	MAP 340/342:	typ. 0.01 %, +/-1 digit
	MAP 334:	typ. 0.03 %, +/-1 digit
	MAP 344:	typ. 0.01 %, +/-1 digit
	MAP 444:	typ. 0.01 %, +/-1 digit
temp. coefficient:	MAP 330/332/334:	typ. 50 ppm / °C
	MAP 340/342/344/444:	typ. 20 ppm / °C
measurement input:		<i>standard:</i> potentiometer: min. 800 Ohm connected load
		<i>option:</i> 0-10 V DC / 0-20 mA DC / 4-20mA DC
		<i>max. datas:</i> voltage: max. 50 V DC (Ri= 1MOhm) current: max. 50 mA DC (Ri= 50 Ohm load) Overvoltage category CAT I
sensor voltage:		for potentiometer: 5.0 V DC, max. 10 mA
logic inputs:		20 - 30 V/ typ. 5 mA, optoisolated
debounce time:		typ. 10 msec., for logic inputs
auxiliary voltage output:		ca. 24 V DC, max. 70 mA unstabilized (depend on load, open voltage max. 30 V DC)
comparator:		only series MAP 332/334/342/344/444: limit value comparator, limit value function MIN/MAX for every limit separatly programmable
hysteresis:		only series MAP 332/334/342/344/444: programmable, for all limits common
optocoupler outputs:		only series MAP 334/344/444: 4x max. 35 V / 30 mA load
relay outputs:		only series MAP 332/334/342/344/444: 2x UM, max. 250 V / 0.5A load
interface:		only series MAP 334/344/444: RS 232-interface dataformat: 9600 bps, 1 start, 8 data, 2 stop, no Parity
ambient temperature:		0 to + 50 °C

protective standard:	EN 60529: frontside IP 40, backside IP 00
EMI:	EN 50082-2 for industrial area
	EN 50081-2 for industrial area
minimal reliability:	-during breakdown irradiation accordingly DIN EN 50082-2 in the frequency range of 27-1000MHz with field strength 10V/m amounts to the accuracy 0,1%. - with Burst - Disturbance accordingly DIN EN 50082-2 with 2kV amounts to the accuracy 0.1%.
dimension:	96 x 48 x 135 mm DIN-panel mount case
connection:	screw-type terminals, 1x15pole, 2x9pole, plug-in type

10 CONNECTION / OPERATING CONTROLS

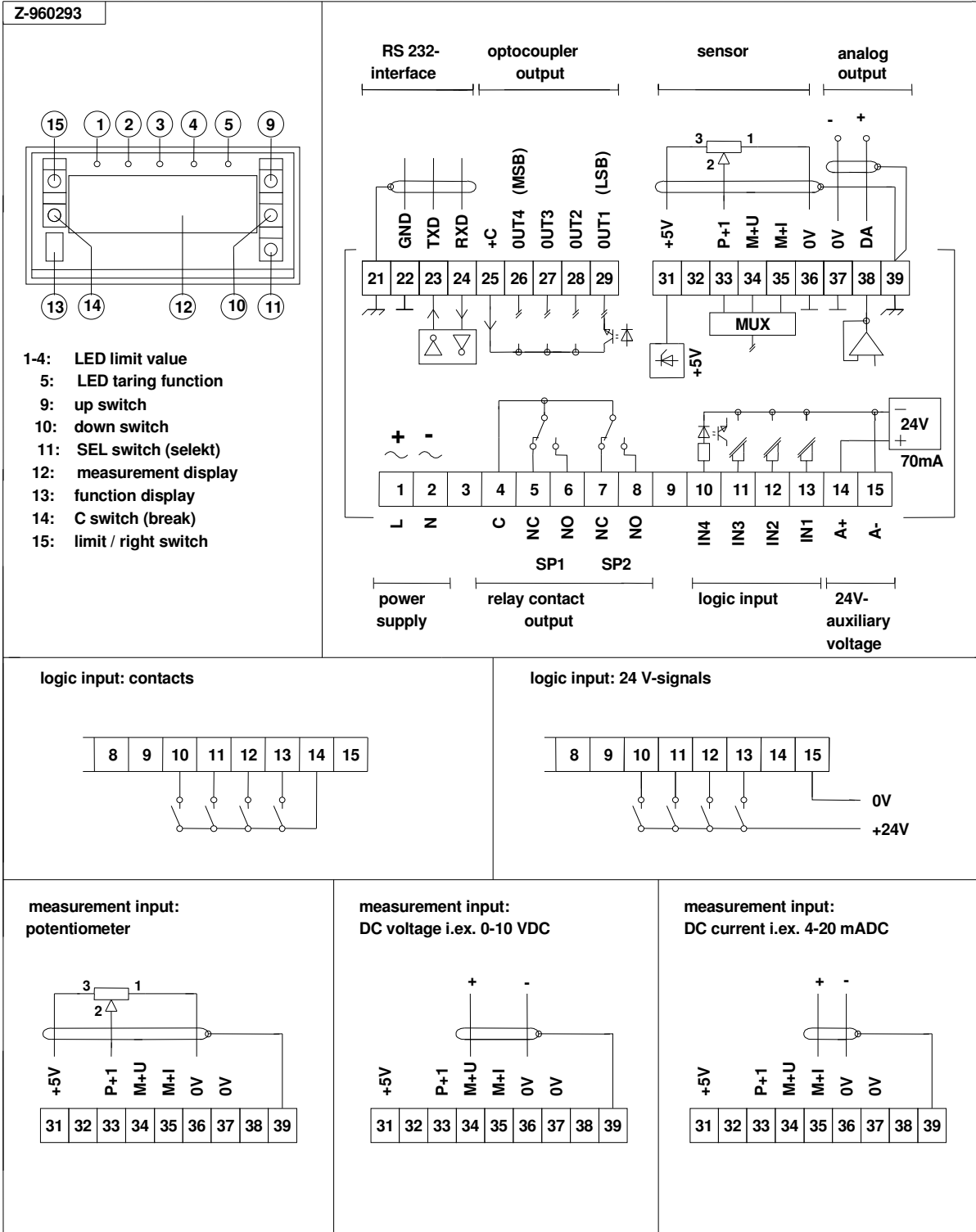

11 DESCRIPTION IN/OUTPUTS

Terminal	Function	Area
1	AC power supply (AC): L (phase) 230V AC (option 110V) DC power supply (DC): + 20...30V DC	supply
2	AC power supply (AC): N 230V AC (option 110V) DC power supply (DC): 0V DC	
3	unused	
4	C: common relay contact of SP1 and SP2	relay outputs
5	NC/SP1: Normally closed contact of limit value relay SP1	
6	NO/SP1: Normally open contact of limit value relay SP1	
7	NC/SP2: Normally closed contact of limit value relay SP2	
8	NO/SP2: Normally open contact of limit value relay SP2	
9	unused	
10	IN4: optoisolated logic input 4 (level: +20...30V DC, terminal 15 common minus-terminal)	logic inputs
11	IN3: optoisolated logic input 3 (level: +20...30V DC, terminal 15 common minus-terminal)	
12	IN2: optoisolated logic input 2 (level: +20...30V DC, terminal 15 common minus-terminal)	
13	IN1: optoisolated logic input 1 (level: +20...30V DC, terminal 15 common minus-terminal)	
14	A+: +24V-auxiliary output (unstabilized, not short circuit protected +20...30V DC/70mA) for supply external sensors, driving the optoisolated inputs IN1...IN4 and/or supply the optoisolated outputs OUT1...OUT4.	auxiliary voltage output
15	A-: Minus- Auxiliary voltage output . This terminal is internal connected to the minus terminal of the optoisolated inputs. At units with DC-power supply: internal connection with terminal 2 (0V power supply).	
21	Screen terminal for interface cable (internal connection with terminal 39).	screen
22	GND: Ground potential of RS232-interface (internal connection with terminal 36/37).	rs232- interface
23	TXD: Transmit data of RS232-interface	
24	RXD: Receiver data of RS232-interface	
25	+C: +24V-terminal for supply the optoisolated outputs OUT1...OUT4	optocoupler- outputs
26	OUT4: optoisolated output 4 (limit value or BCD/HEX-output: MSB)	
27	OUT3: optoisolated output 3 (limit value or BCD/HEX-output)	
28	OUT2: optoisolated output 2 (limit value or BCD/HEX-output)	
29	OUT1: optoisolated output 1 (limit value or BCD/HEX-output: LSB)	
31	+5V: voltage output for supply potentiometric sensors	measuring inputs and sensor supply
32	P+2: unused	
33	P+1: measuring input for a potentiometric sensors (wipersignal)	
34	M+U: voltage measuring input i.e. 0...+10V DC	
35	M+I: current measuring input i.e. 0...+20mA DC	
36	0V: 0V-measuring signal and ground potential for +5V-voltage output	0V-potential
37	0V: 0V-ground potential for analog output (internal connection with term. 36)	
38	DA: analog output 0...+10V DC oder 0/4...+20mA DC	analog output
39	Screen terminal for measuring signals, sensor cable and analog output	screen