

## 1 Allgemeine Beschreibung

Magnetostruktive Wegaufnehmer für direkte, genaue und absolute Messung von Wegen bzw. Längen in der Steuerungs-, Regelungs- und Messtechnik.

## 2 Sicherheitshinweise

### 2.1 Bestimmungsgemäße Verwendung

Der Wegaufnehmer TLM wird zu seiner Verwendung in eine Maschine oder Anlage eingebaut. Er bildet zusammen mit einer Steuerung ein Wegmesssystem und darf auch nur für diese Aufgabe eingesetzt werden.

Bei unbefugten Eingriffen, unzulässiger Anwendung oder Nichtbeachtung der Montagehinweise kommt es zum Verlust von Garantie- und Haftungsansprüchen.

### 2.2 Installation und Inbetriebnahme

Der Wegaufnehmer ist nur von Fachpersonal und unter Berücksichtigung aller geltenden Sicherheitsbestimmungen in Betrieb zu nehmen.

Alle Maßnahmen zum Schutz von Personen bei einem Defekt des Wegaufnehmers müssen vor der Inbetriebnahme getroffen werden.

**Starke magnetische oder elektromagnetische Felder in unmittelbarer Nähe zum Wegaufnehmer können zu fehlerhaften Signalen führen !**

### 2.3 Anschlüsse prüfen

Falsche Verbindungen und Überspannung können zur Beschädigung des Wegaufnehmers führen.

Prüfen Sie deshalb vor dem Einschalten die Anschlüsse immer sorgfältig.

**Achtung:** Potentialdifferenzen zwischen Versorgung GND und Signal GND sind zu vermeiden.  
Durch Potentialdifferenzen zwischen Versorgung GND und Signal GND kann der Wegaufnehmer zerstört werden!

### 2.4 Einschalten des Systems

Bitte beachten Sie, dass das System beim Einschalten unkontrollierte Bewegungen ausführen kann, vor allem wenn die Wegmesseinrichtung Teil eines Regelsystems ist, dessen Parameter noch nicht eingestellt sind. Stellen Sie daher sicher, dass hiervon keine Gefahren ausgehen können.

### 2.5 Messwerte prüfen

Nach dem Austausch eines Wegaufnehmers wird empfohlen, die Ausgangswerte in der Anfangs- und Endstellung des Positionsgebers im Handbetrieb zu überprüfen. (Änderungen oder fertigungsbedingte Streuungen vorbehalten)

### 2.6 Funktionsfähigkeit prüfen

Die Funktionsfähigkeit des Wegmesssystems und aller damit verbundenen Komponenten ist regelmäßig zu überprüfen und zu protokollieren.

### 2.7 Funktionsstörung

Wenn das Wegmesssystem nicht ordnungsgemäß arbeitet, ist es außer Betrieb zu nehmen und gegen unbefugte Benutzung zu sichern.

## 1 General description

This device is a magnetostricitive transducer for direct, precise and absolute measurement of displacements or lengths in control, regulation and measuring applications.

## 2 Safety instructions

### 2.1 Conventional application

The TLM transducer is intended to be installed in a machine or system. Together with a controller it comprises a position measuring system and may only be used for this purpose.

In case of unauthorized modifications, non-permitted usage or non-observance of installation instructions, the warranty and liability claims will be lost.

### 2.2 Installation and startup

The transducer must be installed by qualified personnel in consideration of all relevant safety regulations.

Non-observance of the installation instructions will void any warranty or liability claims.

All personal protection measures in case of a transducer defect or failure must be taken before startup.

**Strong magnetic or electromagnetic fields in close vicinity to the linear transducer may lead to faulty readings !**

### 2.3 Check connections

Improper connections and overvoltage can damage the transducer.

Please always check the connections carefully before turning on the system.

**Caution:** Potential differences between supply voltage GND and signal GND must be avoided.  
With different potentials between supply voltage GND and signal GND the transducer can be destroyed!

### 2.4 Turning on the system

Please note that the system may execute uncontrolled movements when first turned on or when the transducer is part of a closed-loop system whose parameters have not yet been set. Therefore make sure that no hazards can result from these situations.

### 2.5 Check output values

After replacing or repairing a transducer, it is advisable to verify the output values for the start and end position of the position marker in manual mode. (Transducers are subject to modification or manufacturing tolerances)

### 2.6 Check functionality

The functionality of the transducer system and all its associated components should be regularly checked and recorded.

### 2.7 Fault conditions

If the transducer system doesn't operate properly, it should be taken out of service and protected against unauthorized use.

**3 Einbau / Installation**

**3.1 Wegaufnehmer / Transducer**

**Beispiel Teileschlüssel / example ordering code:**

**TLM xxxx 001 xxx xxx**

je Schraube max. 200 Ncm /  
 Tighten to max. 200 Ncm (=283 ozf in)

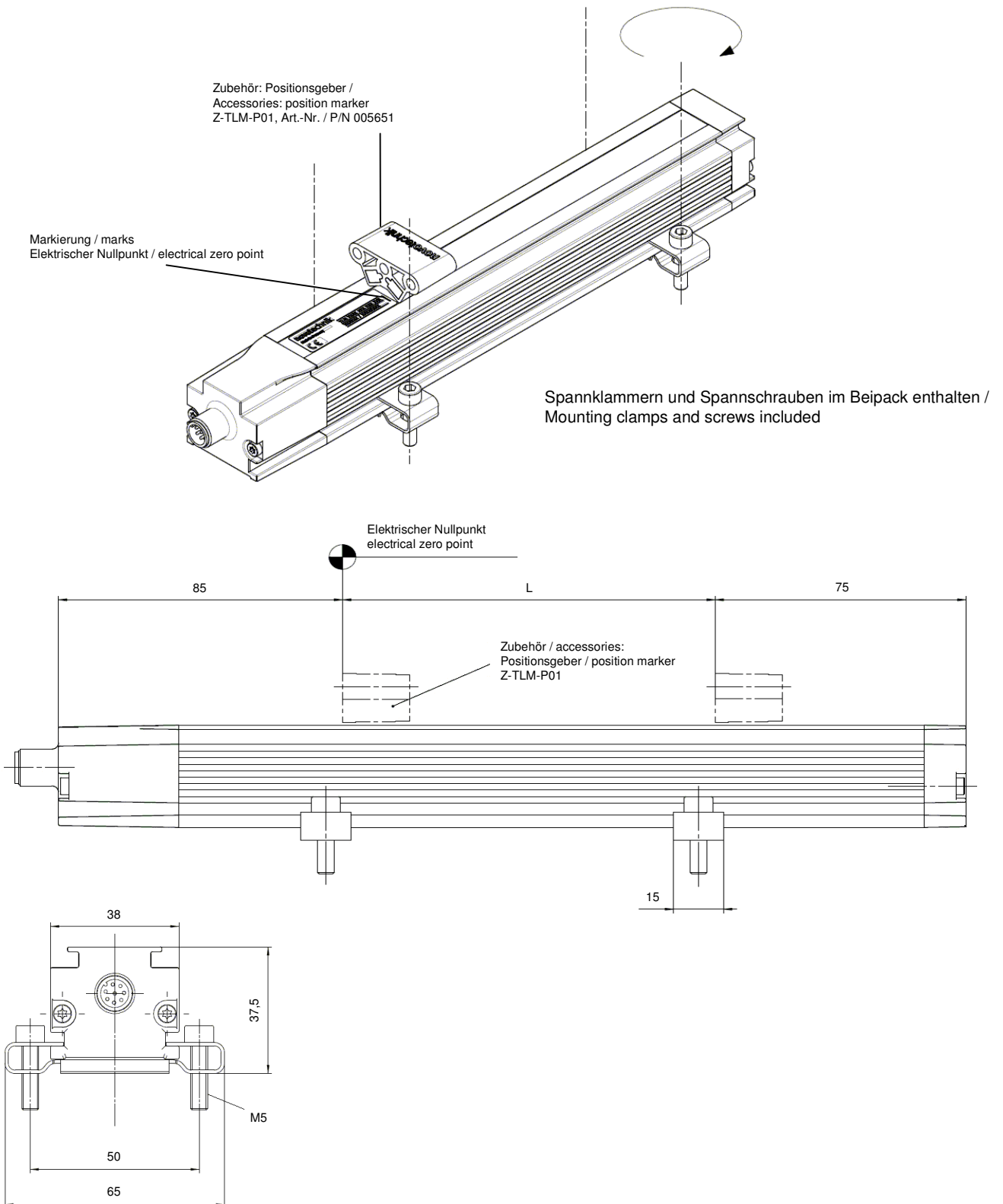

3.2 Elektrischer Anschluss / Electrical connection

3.2.1 Code 105

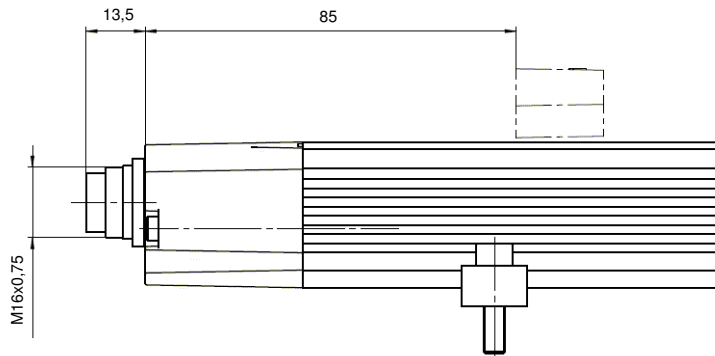

3.2.2 Code 106

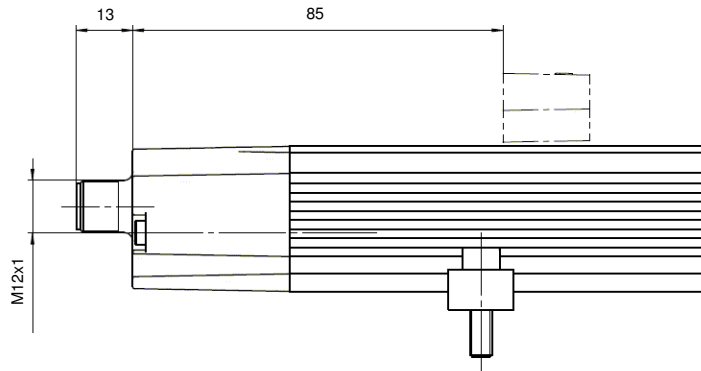

3.2.3 Code 252

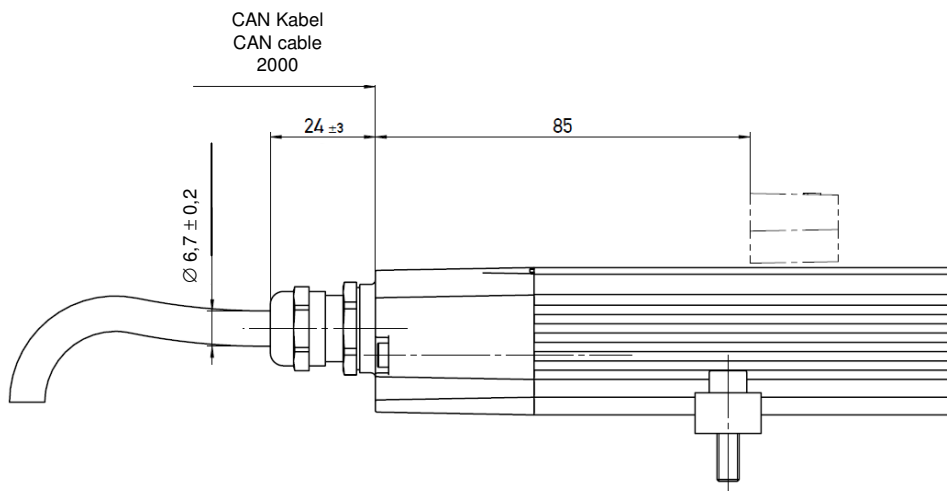

**3.3 Steckerbelegung / Pin configuration**

( Sicht auf den Flanschstecker / front view to the flange connector )

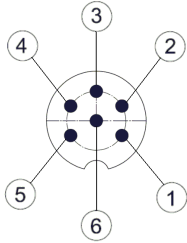

Flanschstecker 6-pol. / 6 pin flange connector  
IEC130-9, DIN 45326

Beispiel Teileschlüssel / example ordering code: TLM xxxx xxx xxx **105**

Zubehör / accessories : Kupplungsdose / straight connector EEM 33-82; IP67; Art.-Nr. / P/N 005639  
Winkeldose / angled connector EEM 33-94; IP67; Art.-Nr. / P/N 005648

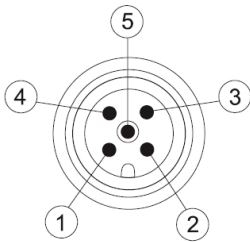

Flanschstecker 5-pol. / 5 pin flange connector  
M12x1, DIN EN 50044

Beispiel Teileschlüssel / example ordering code: TLM xxxx xxx xxx **106**

Zubehör / accessories : Kupplungsdose / straight connector EEM 33-73; IP67; Art.-Nr. / P/N 005645  
Winkeldose / angled connector EEM 33-75; IP67; Art.-Nr. / P/N 005646

**3.4 Positionsgeber / Position marker**

**3.4.1 Z-TLM-P01**

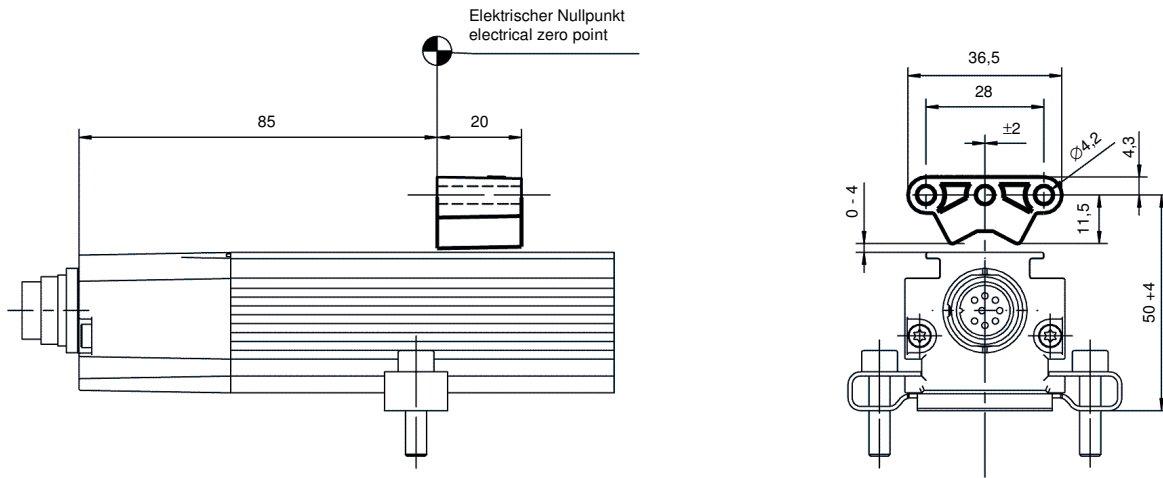

**3.4.2 Z-TLM-P04**

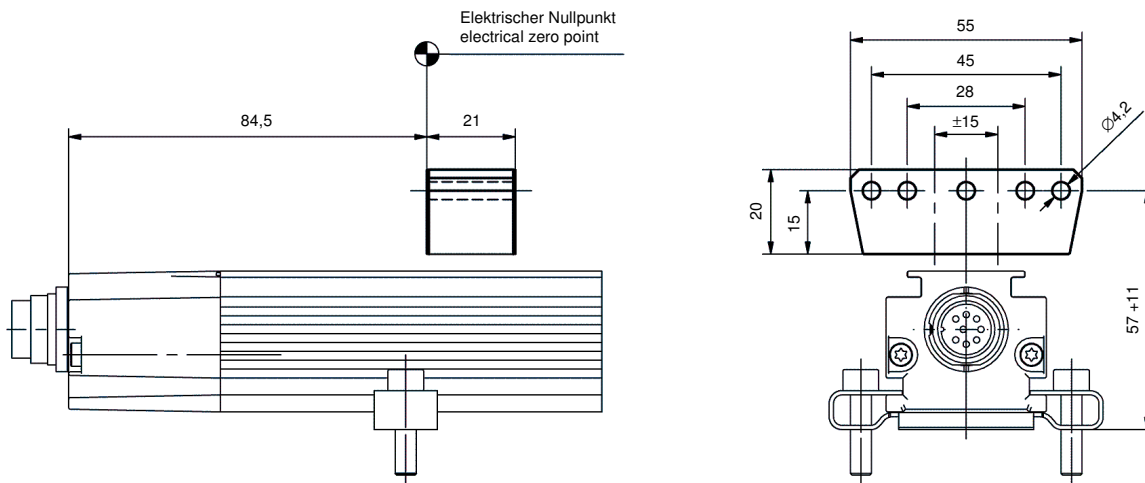

**3.4.3 Z-TLM-P05**

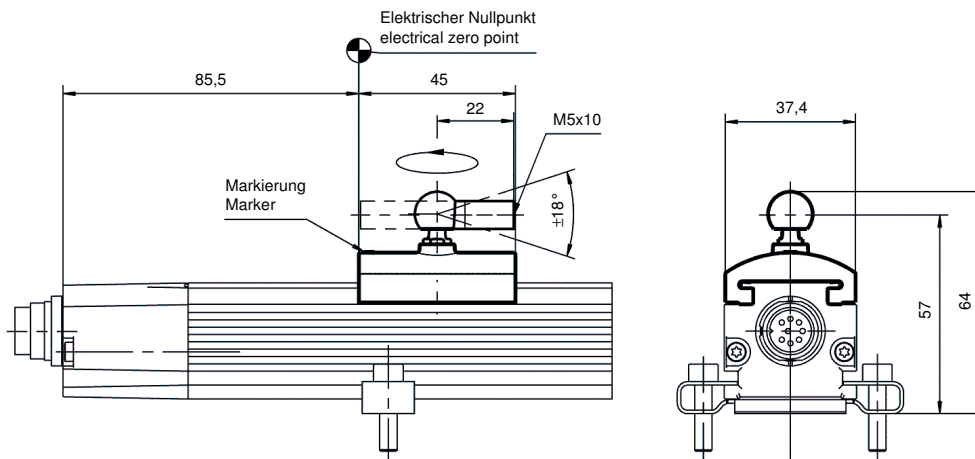

#### 4 Montagehinweis

Bei der Montage der Befestigungsklammern ist das maximale Drehmoment zu beachten. Es wird empfohlen, den Abstand zwischen 2 Befestigungsklammern auf maximal 1000 mm zu beschränken.

Der Positionsgeber (Zubehör) wird im Abstand laut 3.3 zur Profiloberfläche montiert. Die Befestigung des freien Positionsgebers erfolgt mit Schrauben M4. Bei Montage des Positionsgebers ist auf eine ausreichende Ausrichtung desselben zur Messrichtung zu achten.

Ein Potentialausgleich - Stromfluss - über den Kabelschirm ist zu vermeiden. Der Kabelschirm ist mit dem Metallgehäuse des Steckers verbunden – somit auch mit dem Gehäuse TLM. Für kritische Applikationen stehen optional auch Kunststoff-Befestigungsklammern zur Verfügung.

**Der Bereich für den Kabelabgang muss ausreichend dimensioniert werden, der Mindestbiegeradius ist einzuhalten und scharfe Kanten sind zu vermeiden!**

**Bei den Varianten mit mehreren Positionsgebern muss der Abstand zwischen den Positionsgeber jeweils min. 100mm betragen!**

#### Versatz des Positionsgebers:

Ein Höhenversatz des Positionsgebers **Z-TLM-P01** von 0 - 4 mm bewirkt eine Signaländerung von ca. 200 µm/mm.

Ein Seitenversatz des Positionsgebers **Z-TLM-P01** von bis zu 2 mm führt zu keiner Signaländerung.

Ein Höhenversatz des Positionsgebers **Z-TLM-P04** von 4 - 15 mm bewirkt eine Signaländerung von ca. 150 µm/mm. Ein Seitenversatz des Positionsgebers **Z-TLM-P04** von bis zu 2 mm führt zu keiner Signaländerung, bei 2 - 15 mm beträgt die Signaländerung ca. 15 µm/mm.

#### 5 Anschlüsse

##### Beim elektrischen Anschluss unbedingt zu beachten:

Anlage (Versorgung GND) und Schaltschrank (Signal GND) müssen auf gleichem Potential liegen.

Um die elektromagnetische Verträglichkeit (EMV) zu gewährleisten, sind nachfolgende Hinweise unbedingt zu beachten:

- Wegaufnehmer und Steuerung müssen mit einem geschirmten Kabel verbunden werden.
- Schirmung: Geflecht aus Kupfer-Einzeldrähten, 85% Bedeckung.
- Auf der Seite der Steuerung muss der Kabelschirm geerdet, d.h. mit dem Schutzleiter verbunden werden.

#### 6 Elektrische Daten / Electrical data

Versorgungsspannung / Supply voltage: 24 VDC ± 20%

Stromaufnahme / Current draw: CANopen Schnittstelle / CANopen interface ≤ 100 mA typisch / typical

#### 4 Installation Instructions

Note the maximum tightening torque when fastening down the mounting clamps. Recommended maximum distance between 2 mounting clamps is 1000 mm (40 inches).

The position marker (order separately) is installed at a distance according to 3.3 from the top surface of the transducer. The floating position marker is attached using M4 screws. When installing the position marker, observe proper orientation of the position marker to the direction of travel.

Avoid ground loops through the cable shield. Connect the shield to the metal body of the connector, which in turn provides contact to the transducer housing.

For critical applications optionally also plastic mounting clamps are available.

**For the area of the cable please take care that enough space is available, the minimum bending radius has been observed and sharp edges have been avoided!**

**For the versions with several position markers the distance between the position markers must be min. 100mm !**

#### Displacement of the position marker:

A horizontal displacement of the position marker **Z-TLM-P01** of 0 - 4 mm causes a change of signal of approx. 200 µm/mm.

A vertical displacement of the position marker **Z-TLM-P01** of up to 2 mm leads to no change of signal.

A horizontal displacement of the position marker **Z-TLM-P04** of 4 - 15 mm causes a change of signal of approx. 150 µm/mm.

A vertical displacement of the position marker **Z-TLM-P04** of up to 2 mm leads to no change of signal, from 2 - 15 mm the change of signal amounts to approx. 15 µm/mm.

#### 5 Wiring

##### Note the following when making electrical connections:

System (supply voltage GND) and control cabinet (signal GND) must be at the same potential.

To ensure the electromagnetic compatibility, the following instructions must be strictly followed:

- Transducer and controller must be connected using shielded cable.
- Shielding: Copper filament braided, 85% coverage.
- On the controller side the shield must be tied to the connector housing in the BKS connector.

**7 Zubehör (separat zu bestellen)**

- Kupplungsdose 6-pol. IEC130-9 (EEM 33-82 IP 67 ; Art.Nr. 005639)
- Winkeldose 6-pol. IEC 130-9 (EEM 33-94 IP 67; Art.Nr. 005648)
- Kupplungsdose 5-pol. M12x1 (EEM 33-73 IP 67 ; Art.Nr. 005645)
- Winkeldose 5-pol. M12x1 (EEM 33-75 IP 67; Art.Nr. 005646)
- Positionsgeber Z-TLM P01 (Art.Nr. 005651)
- Positionsgeber Z-TLM P04 (Art.Nr. 005654)
- Geführter Positionsgeber Z-TLM P05 (Art.Nr. 005655)

**8 Sonderzubehör auf Anfrage**

- 2 Kunststoff-Befestigungsklammern (Art.Nr. 056027)
- 3 Kunststoff-Befestigungsklammern (Art.Nr. 056028)

**7 Accessories (order separately)**

- Straight connector 6-pin IEC130-9 (EEM 33-82 IP 67 ; P/N 005639)
- Angled connector 6-pin IEC 130-9 (EEM 33-94 IP 67; P/N 005648)
- Straight connector 5-pin M12x1 (EEM 33-73 IP 67 ; P/N 005645)
- Angled connector 5-pin M12x1 (EEM 33-75 IP 67; P/N 005646)
- Position marker Z-TLM P01 (P/N 005651)
- Position marker Z-TLM P04 (P/N 005654)
- Guided position marker Z-TLM P05 (P/N 005655)

**8 Special accessories on request**

- 2 plastic mounting clamps (P/N 056027)
- 3 plastic mounting clamps (P/N 056028)

**9 Bestellcode / ordering code**

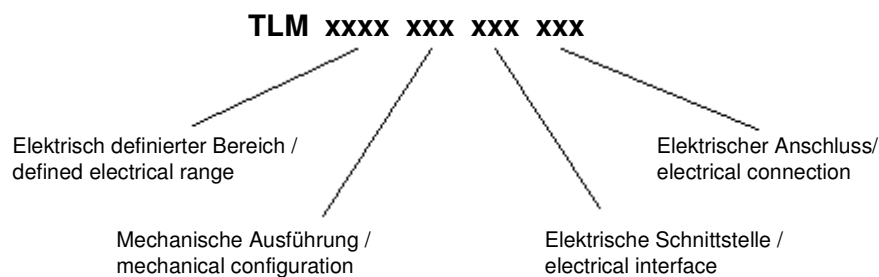

## 9 CANopen

### Contents

1	CANopen	9
1.1	EDS Files	9
1.2	Features	9
1.2.1	Standards	9
1.2.2	Basics based on DS-301, V4.02	9
1.2.3	Basics based on DSP-406, V3.1	10
1.2.4	SDO communication	10
1.2.5	PDO communication	10
1.2.6	LSS (Layer setting service)	10
1.3	Variation of Node-ID	11
1.4	Altering Bit rate	11
1.5	Using Layer Setting service (LSS)	11
1.6	Sensor configuration	12
1.7	Sensor measuring step	12
1.8	Explanations to object library	12
1.9	LSS / Layer Setting Service	13
1.10	Encoder Cams (6300h)	14
1.10.1	Cam state registers	14
1.11	Work Area (6400h)	15
1.11.1	Work Area Supervision	15
1.11.2	Work Area State	15
1.12	TPDOs	16
1.13	Error Handling	16
1.14	Emergency Messages	17
1.15	Object 0x1002: Manufacturer-specific Status	19
1.16	Non-Volatile Storage and Data Restoration	20
2	Physical Assignments	22
2.1	6-pin Flange Connector to IEC130-9, DIN 45326	23
2.2	5-pin Flange Connector to M12x1, DIN EN 50044	23
3	Scope of delivery	24
4	Accessories (order separately)	24
5	Document Changes	24

## 1 CANopen

The basic knowledge of the CAN Bus is required for the good understanding of the present section.

### 1.1 EDS Files

For integration in a common CANopen projecting tool, electronic data sheet (eds) files are served. These files can be downloaded from the Novotechnik Web Site, see Downloads/Operating manuals where also this document can be found.

**Electric data sheet see file TMI\_TLM\_CANopen.eds.**

### 1.2 Features

#### 1.2.1 Standards

Most of the definitions made are according to the following specifications. For making use of all the features that these specifications offer, a knowledge about them is absolutely necessary.

CANopen communication according to CiA Standard	DS-301, V4.02
CANopen Encoder Profile according to CiA Standard	DSP-406, V3.1
CANopen Layer Setting Services according to CiA Standard	DSP-305, V1.1.2

#### 1.2.2 Basics based on DS-301, V4.02

CAN Identifier	Standard 11 Bit according Pre-Defined Connection Set
CAN bit rates	10, 20, 50, 125, <b>250</b> (default), 500, 800, 1000 kBit/s, Auto-baud, setting per LSS or object 0x2001
Node-ID	1- <b>127</b> (default) 255 to be set per LSS or object 0x2000
SYNC	Consumer
Time Stamp	no
Emergency Messages	Producer
Node Guarding	no
Heartbeat	Producer
Non-volatile storage	yes
Program Download	no
NMT Service	Slave

**1.2.3 Basics based on DSP-406, V3.1**

Encoder class	<input checked="" type="checkbox"/> C1 <input type="checkbox"/> C2
Encoder type	Absolute linear encoder
Max. bit bandwidth of position value	24 bit
Encoder Cams Channels to be detected Cams per channel Polarity hysteresis	Pos.ch1, Pos.ch2 4 adjustable yes
Work Area Supervision channels	Pos.ch1, Pos.ch2

**1.2.4 SDO communication**

SDO communication expedited transfer segmented transfer	1 Server yes no
Block transfer	No

**1.2.5 PDO communication**

PDO communication principle	Producer
TPDO's	TPDO1: asynchronous with Event Timer, synchronous TPDO2: synchronous; no RTR's
PDO Mapping	dynamic
max. PDO Mapping logs per PDO	5
mappable objects	pos. ch1/ch2: 0x6020/1; 0x6020/2 velocity-value ch1/ch2: 0x6030/1; 0x6030/2 cam state ch1/ch2 : 0x6300/1; 0x6300/2 work area state ch1/ch2 : 0x6400/1; 0x6400/2

**1.2.6 LSS (Layer setting service)**

LSS Service	slave
-------------	-------

Necessary information for sensor configuration through LSS:

Vendor ID: 0x0182  
 SW version: Product code  
 rev.-No.: 0x020003  
 Serial No.: 8 dig. on sensor label (YYWWxxxx)  
 (Y: year; W: week; xxxx: sequential number)

**1.3 Variation of Node-ID**

Altering Node-ID can be done either by LSS (see chapter 13) or by writing object 0x2000.

Using writing to object 0x2000, non-volatile storage has to be done by writing the“save”- signature (0x65766173) on object 0x1010/1. These changes will become effective after a communication restart or a power up.

Changing the Node-ID will affect all COB-IDs according to the “predefined connection set”.

Example: COB-ID TPDO1 = 0x180 + (node-id).

**1.4 Altering Bit rate**

Altering bit rate can be done either by LSS (see chapter 13) or by writing object 0x2001; in this case, non-volatile storage has to be done by writing the“save”- signature (0x65766173) on object 0x1010/1. These changes will become effective after a communication restart or a power up.

By setting the bit rate to 0xFFFF autobaud will be configured. To detect the bit rate correctly by autobaud, a continuous communication (4-5 messages) has to be provided on the bus.

**1.5 Using Layer Setting service (LSS)**

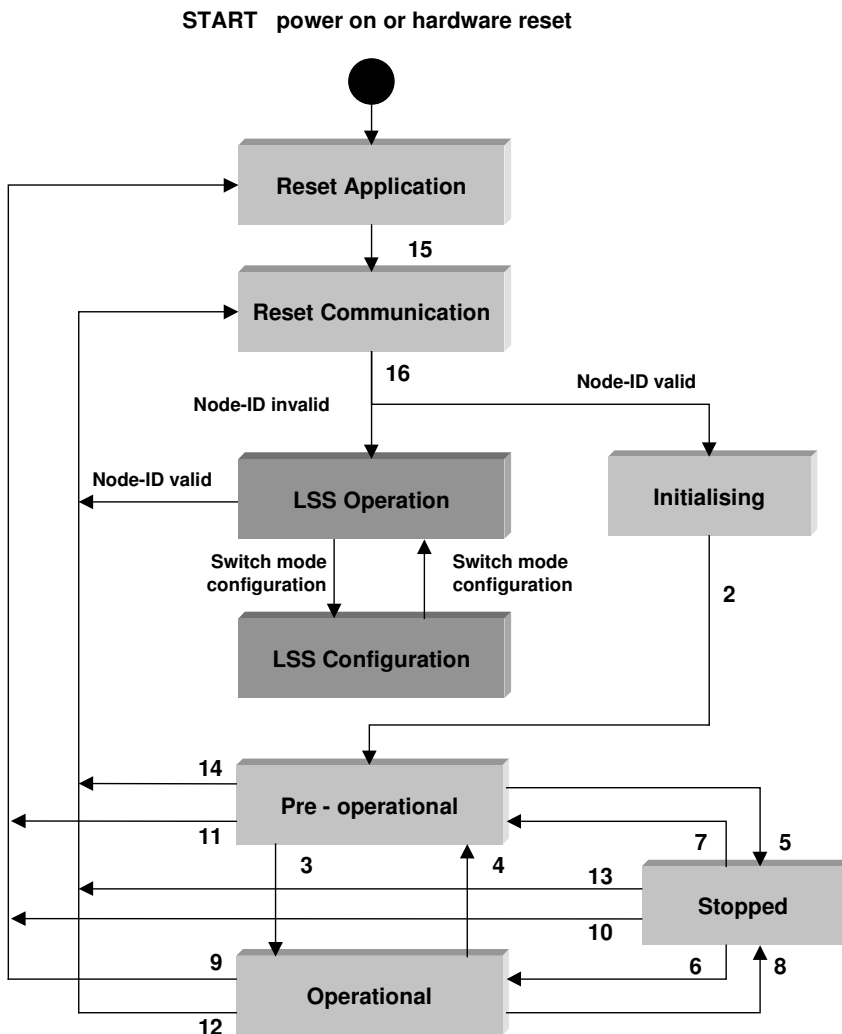

**Picture 1: Overview LSS event machine**

The communication-event machine and the LSS-event machine exist parallelly.



**1.9 LSS / Layer Setting Service**

LSS configuration requires data content in the following objects:

- Objects      1018/1: Vendor ID  
 1018/2: Product Code  
 1018/3: Rev. No.  
 1018/4: Serial No.

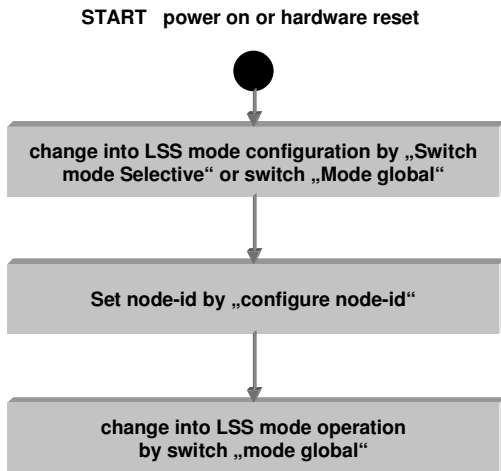

**Picture 2: Necessary Steps for configuration of Node-id via LSS**

Change of Node-ID will cause:

- Automatic alteration of COB-ID's for SDO1, EMCY and Heartbeat and TPDOs.
- Non-volatile Node-ID storage through „Store Configuration“ in the LSS mode configuration.

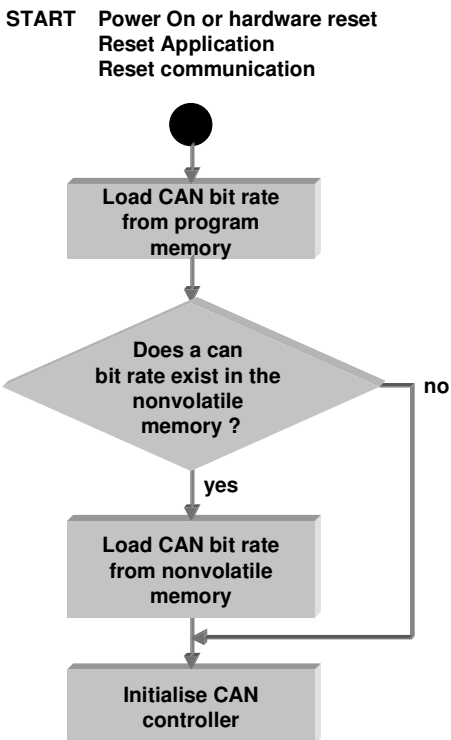

**Picture 3: CAN bit rate Initialization process**

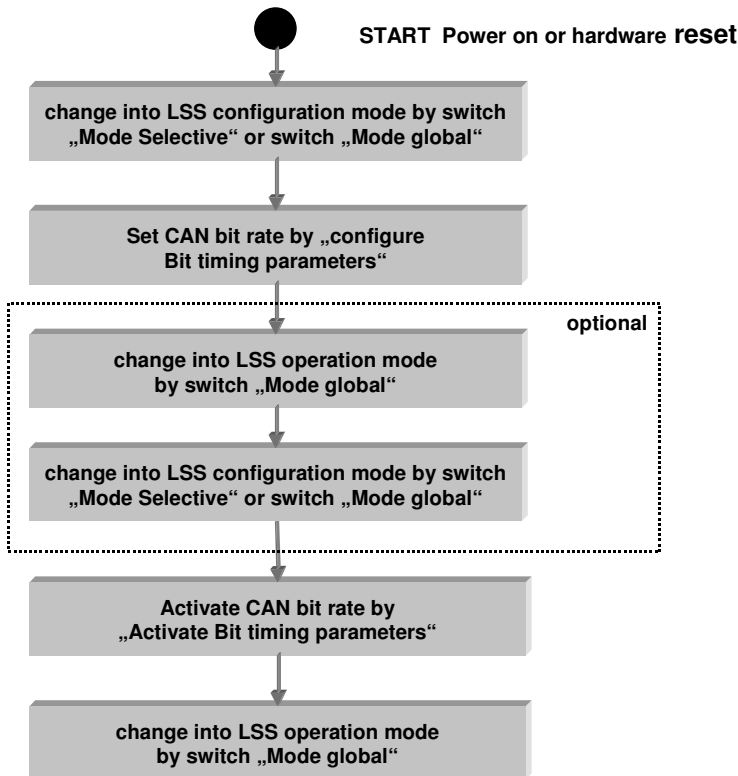

Picture 4: Setting CAN bit rate via LSS

The CAN bit rate can be non-volatile stored by “Store Configuration” in LSS configuration mode.

### 1.10 Encoder Cams (6300h)

Encoder Cams are used to indicate if a position falls below or exceeds a defined value.

Each position channel is fixed to a Cam channel:

Position		Encoder Cam
Index	Subindex	Channel
0x6020	1	1
0x6020	2	2

#### 1.10.1 Cam state registers

Cam enable 0x6301	Cam polarity 0x6302	Cam state 0x6300
0	0	0 cam inactive
	1	1 cam inactive
1	0	0 cam inactive
		1 cam active
	1	0 cam active
		1 cam inactive

Cam active:  
 the current position value is between the upper and lower cam-limit.

Cam inactive:  
 the current position value is not between the upper and lower cam-limit.

The values for Low Limit (0x631x) and High Limit (0x632x) regard the values for preset (0x6010) and measuring step settings (0x6005).

The value of hysteresis (0x633x) is added in direction of motion.  
 A change in cam state causes an EMCY message. The cam state objects (0x6300) are able to be mapped to the TPDOs.

**1.11 Work Area (6400h)**

It is possible for encoders to define a so-called user defined working area.

The main purpose for a work area is to get a high-priority information (via emcy message) when the transducer's position leaves its pre-defined working area.

The actual work area information with work area low limit and work area high limit may be stored in object 6401h. This way, the area state object (6400h) may also be used as software limit switches.

**1.11.1 Work Area Supervision**

Each Work Area channel is fixedly linked to a position channel:

Position		Work Area
Index	Subindex	Channel
0x6020	1	1
0x6020	2	2

**1.11.2 Work Area State**

Condition	State register 0x6400
Position < Work Area Low Limit Position >= Work Area Low Limit	Bit 2 = 1 Bit 2 = 0
Position > Work Area High Limit Position <= Work Area High Limit	Bit 1 = 1 Bit 1 = 0
Position <= Preset Value or Position >= Sensor length otherwise	Bit 0 = 1 Bit 0 = 0

The values for Low Limit (0x6401) and High Limit (0x6402) regard the values for preset (0x6010) and measuring step settings (0x6005).

A change in Work Area state causes an EMCY message. The Work Area state objects (0x6400) are able to be mapped to the TPDOs.

### 1.12 TPDOs

2 TPDOs with each max. 8 mapped entries are provided:

Mappable objects	Number of bytes necessary per TPDO	
	Pos_ch1 Vel_ch1	Pos_ch1 / Vel_ch1 Pos_ch2 / Vel_ch2
0x6020/1	4	4
0x6020/2		4
0x6030/1	2	2
0x6030/2		2
0x6300/1	1	1
0x6300/2		1
0x6400/1	1	1
0x6400/2		1
Total	8 Byte	16 Byte
Number of TPDOs necessary (8 bytes/ TPDO)	1	2

TPDO1 value for Event Timer must always be higher than the value for Inhibit Time (except for value 0).

Failed sending of TPDOs can occur if:

- more TPDOs shall be sent than the CANbus may accept due to insufficient CAN bit rate compared to TPDO/Event Timer;
- excessive bus load or unfavourable setting of COB-ID in the CANopen network prevents TPDO sending.
- Object 0x1800/5- event timer- is set to 0.

### 1.13 Error Handling

Depending on the type of error occurred, the transducer will react accordingly. Refer to table below.

Error Class	Error	Error Message from Sensor
Protocol error	SDO protocol error, corrupted data received via SDO	Abort SDO Transfer*
	PDO protocol error, corrupted data received via PDO	Not relevant, sensor does support TPDOs only
Communication error	CAN bus off CAN error passive CAN overrun CAN buffer overflow	EMCY message**
Process error	Position or sensor error	EMCY message**
	Data error	Abort SDO Transfer* or EMCY message**
Change of state	According to Cams and Work Areas	EMCY Message**

**table 1: error reaction behaviour of transducer**

\*...according to DS-301

\*\* Details see Emergency Messages, next section

1.14 Emergency Messages  
(COB-ID stored in object 1014)

Error Code (hex) Byte 1,2	Additional (hex)			Description
	Byte 3,4	Byte 5,6	Byte 7	
0000	0	0	0	<i>Sensor Error resetted</i>
5000	1	1	0	<i>Sensor Error</i> <u>Cause:</u> An Internal error bit is set. The current process values stay in the object directory; the cam and work area states stay unchanged. If the internal error bit is reset to 0, an EMCY with 0x0000 is sent.
5000	1	2	0	<i>Wrong Sensor Mapping</i> <u>Cause:</u> sensor doesn't detect ist configuration pos1/2 or pos1/vel1. <u>Reaction:</u> sensor changes into PRE-OPERATIONAL mode. NMT Master cannot set the sensor into OPERATIONAL mode, until error has been eliminated and sensor has been reset through power off/on. Attempted setting into OPERATIONAL will result in repeated EMCY message sending.
5000	1	3	1 2	<i>System Data Error</i> <u>Cause:</u> sensor system data exceed allowed internal data range. <u>Reaction:</u> sensor changes into PRE-OPERATIONAL mode. NMT Master cannot set the sensor into OPERATIONAL mode, until error has been eliminated and sensor has been reset through power off/on. Attempted setting into OPERATIONAL will result in repeated EMCY message sending. <i>Wrong Vendor ID</i> <i>Wrong Scale</i>
5000	1	4	0	<i>Wrong Sensor Resolution</i> <u>Cause:</u> sensor has been set to wrong resolution internally. <u>Reaction:</u> sensor changes into PRE-OPERATIONAL mode. NMT Master cannot set the sensor into OPERATIONAL mode, until error has been eliminated and sensor has been reset through power off/on. Attempted setting into OPERATIONAL will result in repeated EMCY message sending.
5000	1	5	0	<i>Unexpected System Data</i> <u>Cause:</u> application received sensor-internal system data instead of process data during normal operation mode. <u>Reaction:</u> sensor changes into PRE-OPERATIONAL mode. System data is being computed as if power-up had occurred (system data are being checked and serial number and product code, if correct, is being stored in EEPROM). If system data are correct, normal operation can continue afterwards.

table 2: Emergency messages (1 of 2)

Error Code (hex) Byte 1,2	Additional (hex)			Description
	Byte 3,4	Byte 5,6	Byte 7	
5000	1	6	0	<p><i>No System Data</i></p> <p><u>Cause:</u> application has not received system data after power-up. Sensor configuration is not detected internally.</p> <p><u>Reaction:</u> sensor changes into PRE-OPERATIONAL mode. NMT Master cannot set the sensor into OPERATIONAL mode, until error has been eliminated and sensor has been reset through power off/on.</p> <p>Attempted setting into OPERATIONAL will result in repeated EMCY message sending.</p>
5000	2	1	0	<p><i>Invalid Serial Number in EEPROM</i></p> <p><u>Cause:</u> the serial number and product code stored in the EEPROM is invalid.</p> <p><u>Reaction:</u> sensor changes into PRE-OPERATIONAL mode. NMT Master cannot set the sensor into OPERATIONAL mode, until error has been eliminated and sensor has been reset through power off/on.</p> <p>Attempted setting into OPERATIONAL will result in repeated EMCY message sending.</p>
6000	1	0	0	<p><i>Insufficient Event Timer Value</i></p> <p><u>Cause:</u> CAN bit rate has been set to a low value and an insufficient Event Timer value has been set for TPDO1 accordingly.</p> <p><u>Reaction:</u> TPDO1 sending will occur partially.</p>
8110	1	0	0	<p><i>CAN Controller Overflow</i></p> <p><u>Cause:</u> data buffers of CAN controller are still holding data and cannot accept new entries. Data is being lost.</p> <p><u>Reaction:</u> none</p>
8110	2	0	0	<p><i>CAN Buffer Overflow</i></p> <p><u>Cause:</u> data buffers of CANopen library are still holding data and cannot accept new entries. Data is being lost.</p> <p><u>Reaction:</u> none</p>
8120	0	0	0	<p><i>CAN Error Passive</i></p> <p><u>Cause:</u> CAN controller has detected communication errors and is reporting error passive.</p> <p><u>Reaction:</u> none</p>
8140	0	0	0	<p><i>CAN Recovered From Bus-Off</i></p> <p><u>Cause:</u> CAN controller registered too many sending errors. CAN communication could be restored afterwards.</p> <p><u>Reaction:</u> none</p>
9080	Chan.	Cam	state	<p><i>Encoder CAM</i></p> <p><u>Cause:</u> the state of cam / chan. has changed. State is coded according to 0x6300.</p> <p><u>Reaction:</u> none</p>
9090	Chan.	0	State	<p><i>Work Areas</i></p> <p><u>Cause:</u> the state of Work Area / chan. has changed. State is coded according to 0x6400.</p> <p><u>Reaction:</u> none</p>

table 3: Emergency messages (2 of 2)

**1.15 Object 0x1002: Manufacturer-specific Status**

This object shows the sensor status bit code and is used for internal process control purposes.

For servicing this information can be requested via SDO.

Bit	Definition (bit value = 1)
16	TMI receiving process data
15	TPDO1 Event Timer Value insufficient for set CAN bit rate
14	EEPROM: CRC error, invalid data
13	Wrong Sensor Mapping
12	System Data Error: Wrong Vendor ID
11	System Data Error: Wrong Scale
9	Wrong Sensor Resolution
8	System Data received from sensor
7	No System Data received from sensor
6	CAN Controller Overflow
5	CAN Buffer Overflow
4	CAN Error Passive
3	CAN Bus-Off
2	CAN Bus-Off Timer started
0-1	NMT Condition of Sensor %11 STOPPED %10 OPERATIONAL %01 PRE-OPERATIONAL %00 INITIALISATION

**1.16 Non-Volatile Storage and Data Restoration**

Default values for all data objects are stored in the program memory.

For the following data objects an application-specific default value may be stored in the non-volatile memory, additionally:

Object index (hex)	Store					Load				Delete							
	LSS	Object 1010/				Auto	Boot-Up	Reset Comm.	Object 1011/				Reset Appl.	Object 1010/			
		1	2	3	4				1	2	3	4		1	2	3	4
1800/2	-	x	x	-	-	-	x	x	*	*	-	-	x	x	x	-	-
1800/3																	
1800/5																	
1A00/0																	
1A00/1																	
1A00/2																	
1A00/3																	
1A00/4																	
1A00/5																	
1801/2																	
1801/3																	
1A01/0																	
1A01/1																	
1A01/2																	
1A01/3																	
1A01/4																	
1A01/5																	
1017/0																	
2000/0	x	x	-	-	x	-	x	x	*	-	-	*	x	x	-	-	x
2001/0																	
6005/1	-	x	-	x	-	-	x	-	*	-	*	-	x	x	-	x	-
6005/2																	
6010/1																	
6010/2																	
6302/1																	
6302/2																	
6310/1																	
6310/2																	
6311/1																	
6311/2																	
6312/1																	
6312/2																	
6313/1																	

Object index (hex)	Store					Load				Delete								
	LSS	Object 1010/				Auto	Boot-Up	Reset Comm.	Object 1011/				Reset Appl.	Object 1010/				
		1	2	3	4				1	2	3	4		1	2	3	4	
6313/2																		
6320/1																		
6320/2																		
6321/1																		
6321/2																		
6322/1																		
6322/2																		
6323/1																		
6323/2																		
6330/1																		
6330/2																		
6331/1																		
6331/2																		
6332/1																		
6332/2																		
6333/1																		
6333/2																		
6401/1																		
6401/2																		
6402/1																		
6402/2																		
1800/1	-	-	x	-	-	-	x	x	*	*	-	-	x	x	x	-	-	
1801/1																		
1018/4	-	-	-	-	-	x	-	x	-	-	-	-	x	-	-	-	-	
1018/2																		

x ... non-volatile user stored parameters

\* ... parameters from program memory

• **Storage via LSS:**

Data must be stored through the LSS Service Configuration/Store while in LSS Configuration Mode.

• **Object 0x1010:**

Data is stored in the non-volatile memory during encryption of object 0x1010 with „save“ signature (0x65766173).

• **Auto:**

Application will store data automatically in the non-volatile memory.

• **Load at Boot-up:**

CANopen Library will upload data from the non-volatile memory during the booting procedure.

• **Reset Communication:**

During Reset Communication data is being uploaded from the non-volatile memory.

• **Object 0x1011:**

Encryption of object 0x1011 with the signature „load“ (0x64616663) will upload data from the non-volatile memory. Default settings are being restored.

• **Reset Application:**

During Reset Application data is being uploaded from the non-volatile memory

• **Delete Via Object 0x1010:**

Additionally to the functionality defined in CiA standard DS-301, CANopen Library offers the possibility to delete data in the non-volatile memory. Delete process is initiated by sending the signature "kill" (0x6B696C6C) to object 0x1010.

Data encryption to the non-volatile memory is only admitted in condition PRE\_OPERATIONAL.

**2 Physical Assignments**

Signal description	Notation
CAN_L bus line (dominant low)	CAN_L or CAN <sub>low</sub> or CAN-
CAN:H bus line (dominant high)	CAN_H or CAN <sub>high</sub> or CAN+
CAN Ground	CAN_GND or CAN <sub>GND</sub> or Ground or GND
Optional CAN Shield	CAN_SHLD or CAN <sub>SHIELD</sub> or Shield or SHLD
Optional CAN external positive supply	CAN_V+ or CAN <sub>V+</sub> or V+ or UC or U <sub>CAN</sub>
Optional Ground	OPT_GND or GND <sub>opt</sub> or V- or 0V

**2.1 6-pin Flange Connector to IEC130-9, DIN 45326**

The last 3 digits of ordering code are addressed.  
 Transducer P/N example: TLM xxxx xxx 6xx 105

Optional straight connector:  
 EEM 33-82; Protection Class IP67; Part No. 005639

Optional right angle connector:  
 EEM 33-94; Protection Class IP67; Part No. 005648

Pin	Signal	Description
1	CAN_L	CAN_L bus line (dominant low)
2	CAN_H	CAN_H bus line (dominant high)
3	(CAN_SHLD)	Optional CAN Shield (internally connected to CAN_GND)
4	-	nc
5	(CAN_V+)	Optional CAN external positive supply (dedicated for supply of transceiver and optocouplers, if galvanic isolation of the bus node applies)
6	CAN_GND	Ground / 0V / V- (internally connected to CAN_SHLD)

**2.2 5-pin Flange Connector to M12x1, DIN EN 50044**

The last 3 digits of ordering code are addressed.  
 Transducer P/N example: TLM xxxx xxx 6xx 106

Optional straight connector:  
 EEM 33-73; Protection Class IP67; Part No. 005645

Optional right angle connector:  
 EEM 33-75; Protection Class IP67; Part No. 005646

Pin	Signal	Description
1	(CAN_SHLD)	Optional CAN Shield (internally connected to CAN_GND)
2	(CAN_V+)	Optional CAN external positive supply (dedicated for supply of transceiver and optocouplers, if galvanic isolation of the bus node applies)
3	CAN_GND	Ground / 0V / V- (internally connected to CAN_SHLD)
4	CAN_H	CAN_H bus line (dominant high)
5	CAN_L	CAN_L bus line (dominant low)

**2.3 4-wire Cable exit**

The last 3 digits of ordering code are addressed.  
 Transducer P/N example: TLM xxxx xxx 6xx 252

Cable	Signal	Description
Shield	(CAN_SHLD)	Optional CAN Shield (internally connected to CAN_GND)
RD rot/ red	(CAN_V+)	Optional CAN external positive supply (dedicated for supply of transceiver and optocouplers, if galvanic isolation of the bus node applies)
BK schwarz/ black	CAN_GND	Ground / 0V / V- (internally connected to CAN_SHLD)
WH weiss/ white	CAN_H	CAN_H bus line (dominant high)
BU blau/ blue	CAN_L	CAN_L bus line (dominant low)

**3 Scope of delivery**

TLM: Z46 mounting clamps (quantity varies with transducer length).

**4 Accessories (order separately)**

- Necessary: Position marker (diverse types, see separate datasheet)
- M12x1 straight female connector with cable, 2m (EEM 33-86 IP 67 ; P/N 005629)
- M12x1 right-angle female connector with cable, 2m (EEM 33-87 IP 67; P/N 005630)
- Other cable lengths available (see datasheet)

**5 Document Changes**

<i>Version</i>	<i>Änderung</i>	<i>Datum</i>	<i>Bearb</i>
	<ul style="list-style-type: none"> <li>• Vorabversion "Instructions of use TLM TMI CANopen english.pdf"</li> </ul>	09.05.06	VM/ss
1_00	<ul style="list-style-type: none"> <li>• Urzustand: Gebrauchsanleitung TLM TMI CAN englisch.doc. Mit EE/Schnell besprochen.</li> </ul>	01.08.06	VM/ss
1_01	<ul style="list-style-type: none"> <li>• Variante 2 Positionsgeber ergänzt</li> </ul>	19.09.06	VM/ss
1_02	<ul style="list-style-type: none"> <li>• Variante Pos1/Pos2 entfällt</li> </ul>	06.10.06	VM/ss
2_00	<ul style="list-style-type: none"> <li>• TMI und TLM Anleitung separat neu aufgebaut. Anleitung zu CANopen wird unverändert übernommen.</li> </ul>	05.03.08	VL/gt
02	<ul style="list-style-type: none"> <li>• Kabelbelegung hinzugefügt</li> </ul>	24.02.09	PL/ch